

Track Reconstruction in the ATLAS Inner Detector

acknowledgements:

I'd like to thank my colleagues in ATLAS for providing the excellent results I'll try to summarize in the following and for their help in preparing this seminar !



Outline

- short introduction
- expected tracking performance
- commissioning of Inner Detector reconstruction
 - ➔ calibration, tracking, alignment, material, ...
- tracking performance
 - ➔ especially in jets and with pileup
 - ➔ vertexing and b-tagging
- upgrade
 - ➔ expected performance improvements with the Insertable B-Layer (IBL)
 - ➔ FTK as a fast track trigger and GPU based tracking studies



Introduction

- broad **physics program** covered by **ATLAS**
 - ➔ general purpose pp experiment to cover:
 - SM QCD/W/Z/top, Higgs, SUSY, Exotics, ...
 - some aspects in b-physics
 - ability to do heavy ion physics
- **detector** designed to optimize physics performance
 - ➔ at design luminosities ($10^{34} \text{ cm}^{-2}\text{s}^{-1}$) and pileup (~ 23 min.bias events)
 - ➔ possibly sustain heavy ion “central” event multiplicities
- task of **event reconstruction** is to identify objects
 - ➔ e/ μ / τ leptons, photons, (b) jets, missing E_T , exclusive hadronic states...
 - ➔ requires **combining information** from tracking detector with calorimetric and muon spectrometer measurements
 - ➔ **tracking** is a central aspect of the event reconstruction



Introduction

- requirements on ATLAS Inner Detector
 - ➔ **precision tracking** at LHC luminosities (central heavy ion event multiplicities) with a hermitic detector covering 5 units in η
 - ➔ precise **primary/secondary vertex** reconstruction and to provide excellent **b-tagging in jets**
 - ➔ reconstruction of **electrons** (and converted photons)
 - ➔ tracking of **muons** combined with muon spectrometer, good resolution over the full accessible momentum range
 - ➔ enable (hadronic) **tau**, exclusive **b-** and **c-hadron** reconstruction
 - ➔ provide **particle identification**
 - transition radiation in ATLAS TRT for **electron identification**
 - as well dE/dx in Pixels or TRT
 - ➔ not to forget: enable fast tracking for **(high level) trigger**
- constraints on detector design
 - ➔ **minimize material** for best precision and to minimize interactions before the calorimeter
 - ➔ increasing **sensor granularity** to reduce occupancy
 - increase number of electronics channels and heat load
 - leading to more material



ATLAS Inner Detector Layout

- 3 subsystems:

- ➔ 3 layer **Pixel** system, 3 endcap disks

- 1744 Pixel modules
- 80.4 million channels
- pitch $50\ \mu\text{m} \times 400\ \mu\text{m}$
- total of $1.8\ \text{m}^2$

- ➔ 4 layers of small angle stereo strips, 9 endcap disks each side (**SCT**)

- 4088 double sided modules
- 6.3 million channels
- pitch $80\ \mu\text{m}$, $40\ \text{mrad}$ stereo angle
- total of $60\ \text{m}^2$

- ➔ Transition Radiation Tracker (**TRT**)

- typically 36 hits per track
- transition radiation to identify electrons
- total of 350K channels

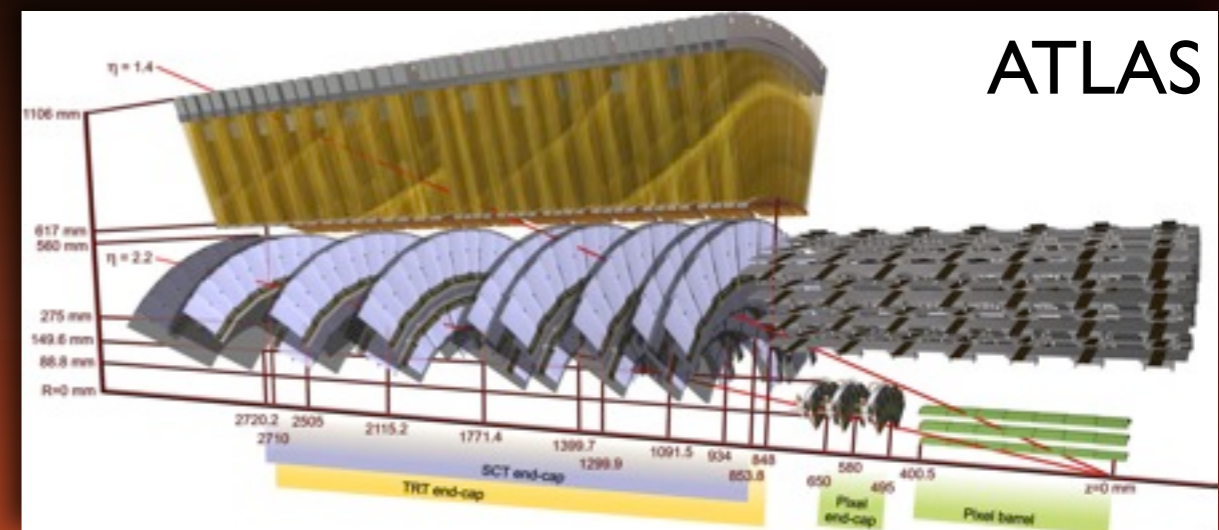
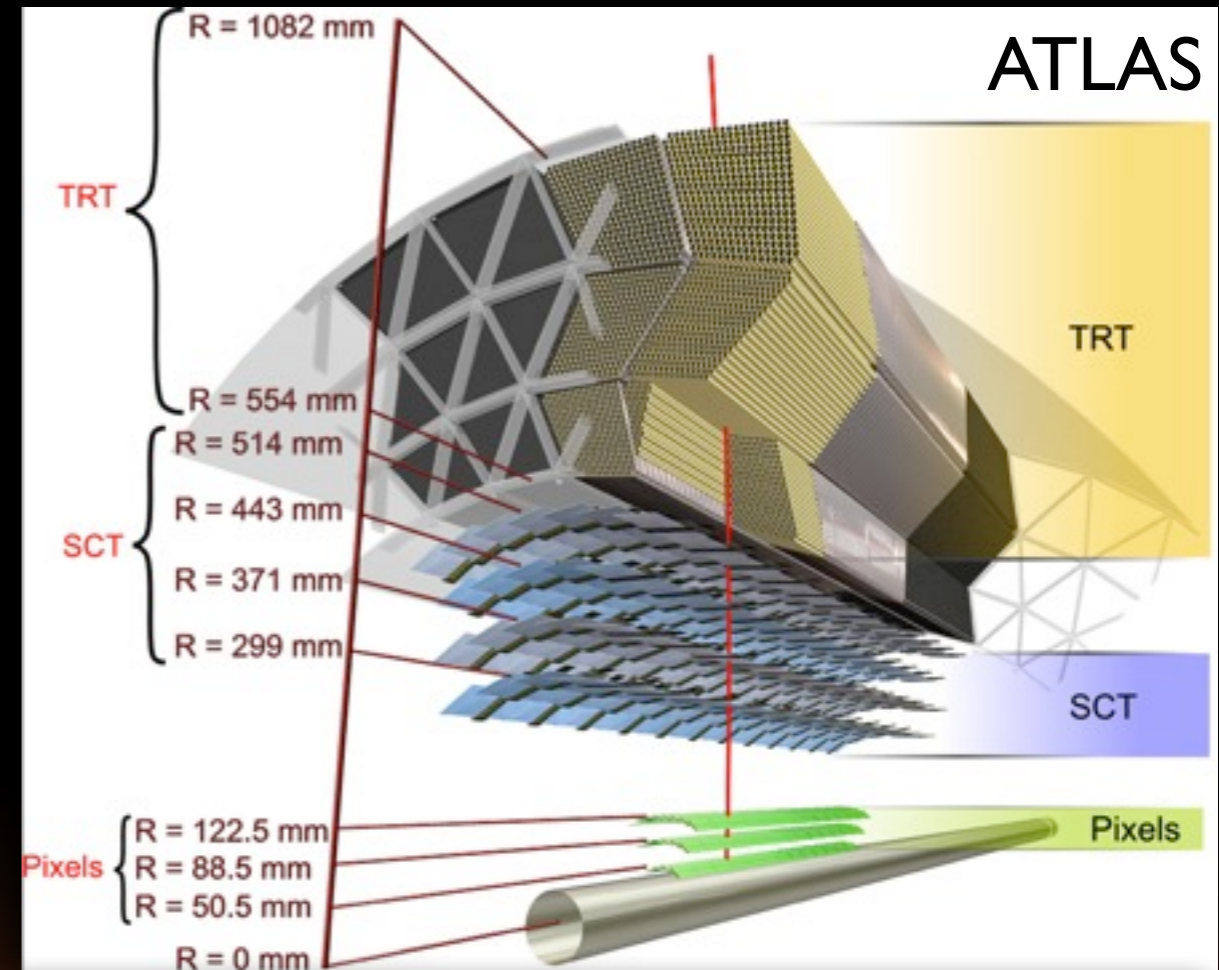



ATLAS Track Reconstruction Chain

pre-processing

- ➔ Pixel+SCT clustering
- ➔ TRT drift circle formation
- ➔ space points formation

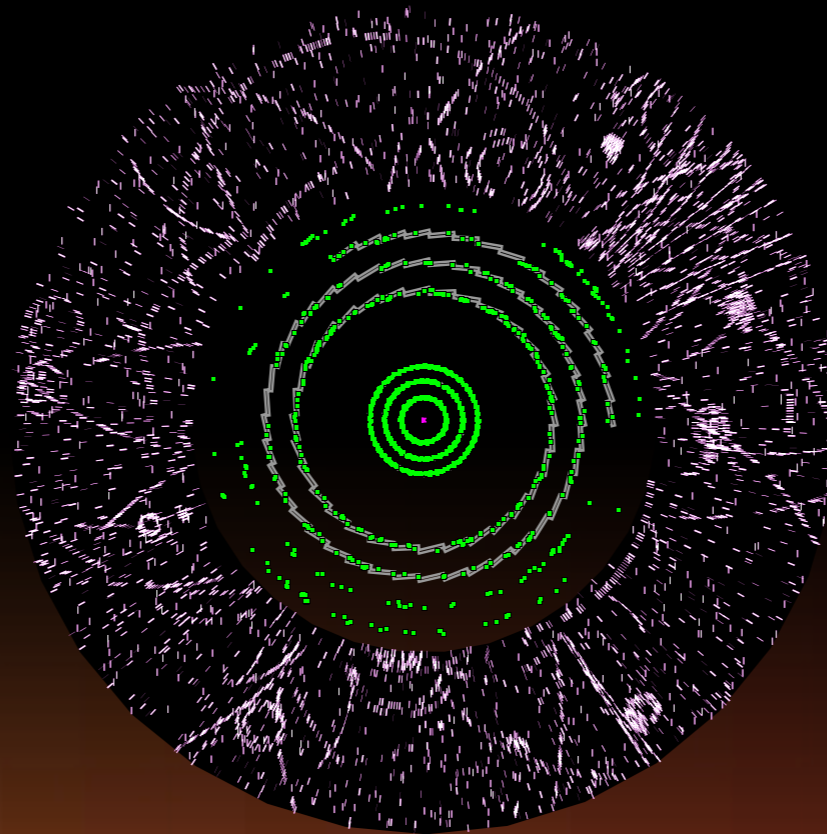



ATLAS Track Reconstruction Chain

pre-processing

- ➔ Pixel+SCT clustering
- ➔ TRT drift circle formation
- ➔ space points formation

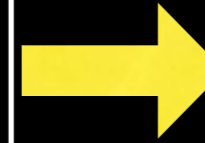

combinatorial track finder

- ➔ iterative :
 1. Pixel seeds
 2. Pixel+SCT seeds
 3. SCT seeds
- ➔ restricted to roads
- ➔ bookkeeping to avoid duplicate candidates

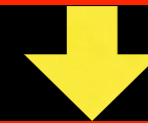

ambiguity solution

- ➔ precise least square fit with full geometry
- ➔ selection of best silicon tracks using:
 1. hit content, holes
 2. number of shared hits
 3. fit quality...



extension into TRT

- ➔ progressive finder
- ➔ refit of track and selection

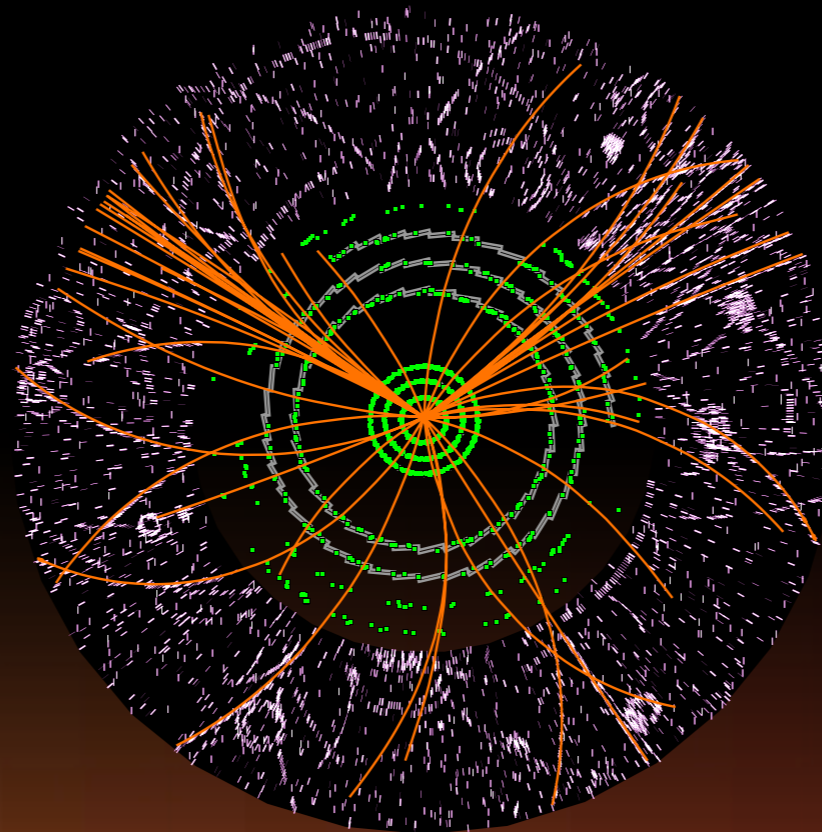



ATLAS Track Reconstruction Chain

pre-processing

- ➔ Pixel+SCT clustering
- ➔ TRT drift circle formation
- ➔ space points formation

combinatorial track finder

- ➔ iterative :
 1. Pixel seeds
 2. Pixel+SCT seeds
 3. SCT seeds
- ➔ restricted to roads
- ➔ bookkeeping to avoid duplicate candidates

standalone TRT

- ➔ unused TRT segments

ambiguity solution

- ➔ precise fit and selection
- ➔ TRT seeded tracks

TRT seeded finder

- ➔ from TRT into SCT+Pixels
- ➔ combinatorial finder

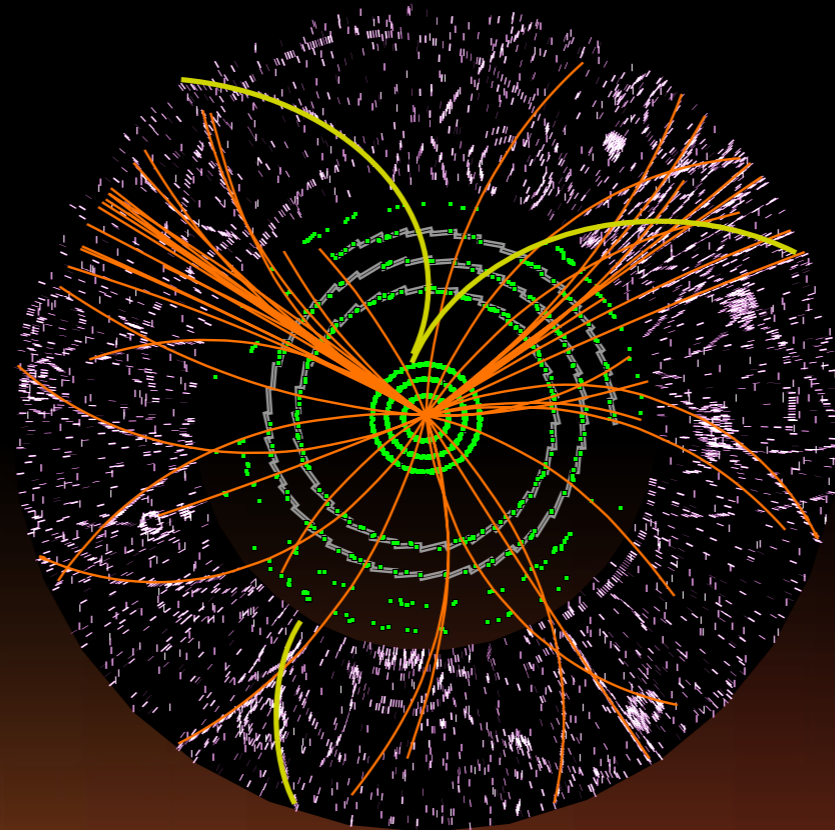

ambiguity solution

- ➔ precise least square fit with full geometry
- ➔ selection of best silicon tracks using:
 1. hit content, holes
 2. number of shared hits
 3. fit quality...

TRT segment finder

- ➔ on remaining drift circles
- ➔ uses Hough transform

extension into TRT

- ➔ progressive finder
- ➔ refit of track and selection





ATLAS Track Reconstruction Chain

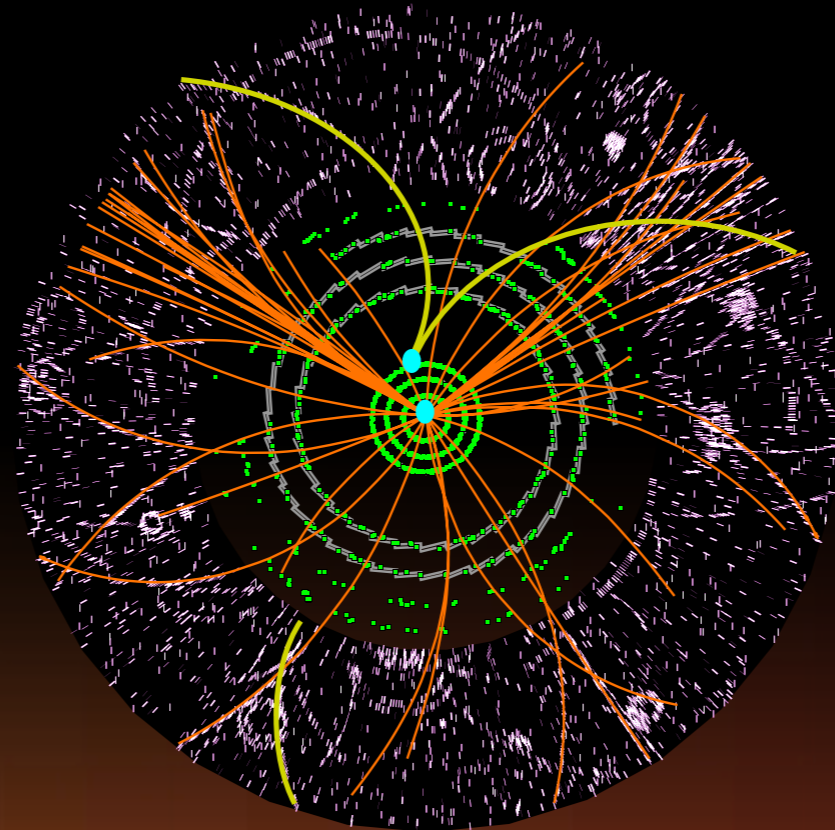
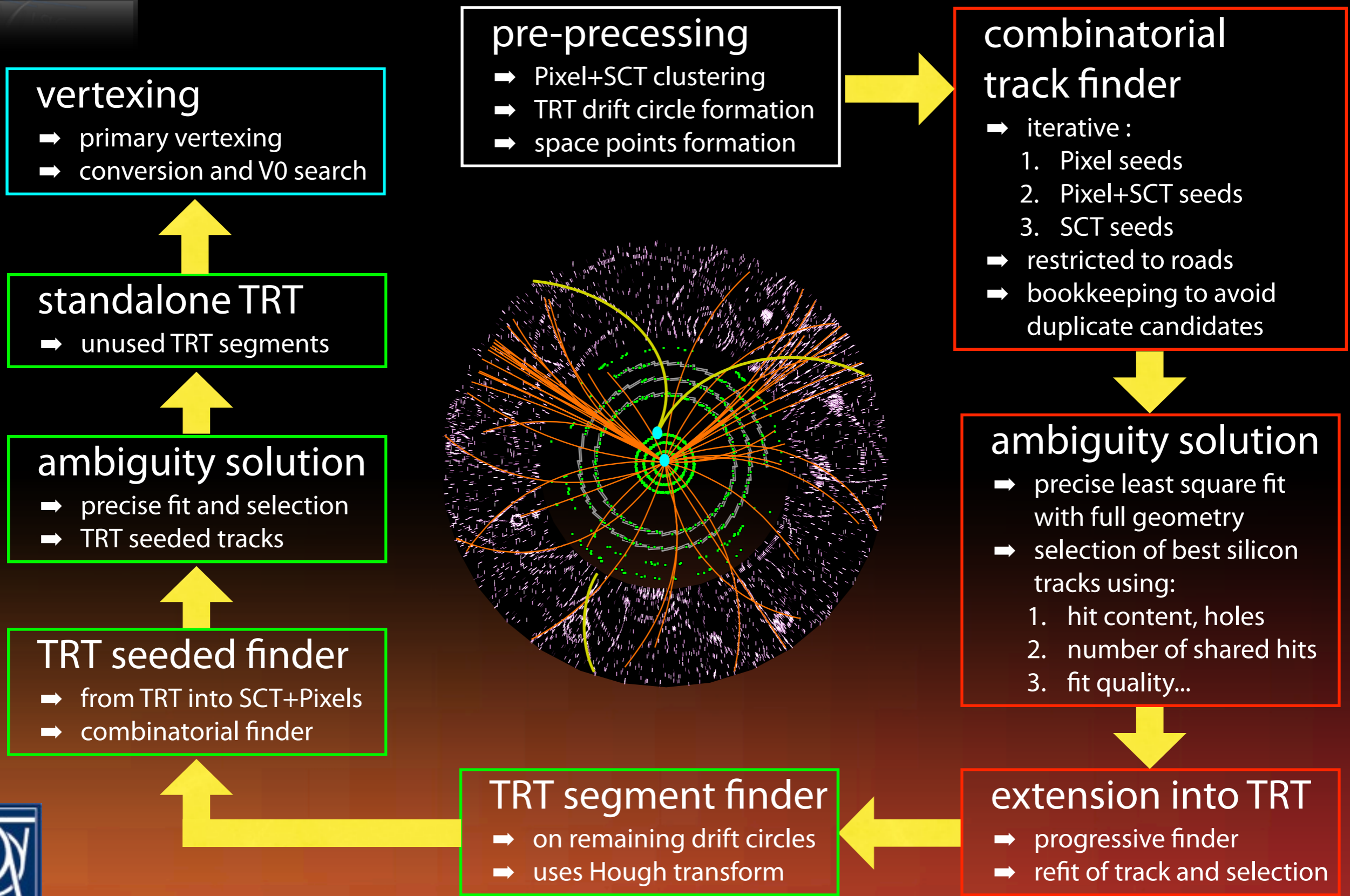

Expected Performance

- excellent preparation before startup

- ➔ more than 10 years of simulation and test beam
- ➔ cosmics data taking in 2008 and 2009
- ➔ payed off last year !

- detailed simulation studies

- ➔ document expected performance in TDRs
- ➔ few of the known **critical items**:
 - **material effects** limit efficiency and resolution at low p_T
 - good (local) alignment for b-tagging
 - momentum scale and alignment "**weak modes**"

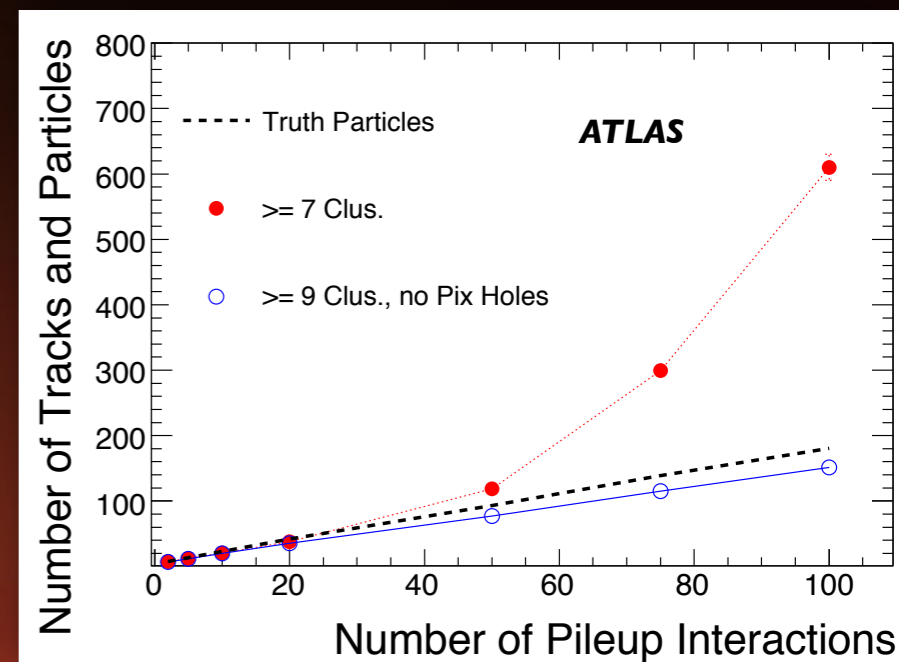
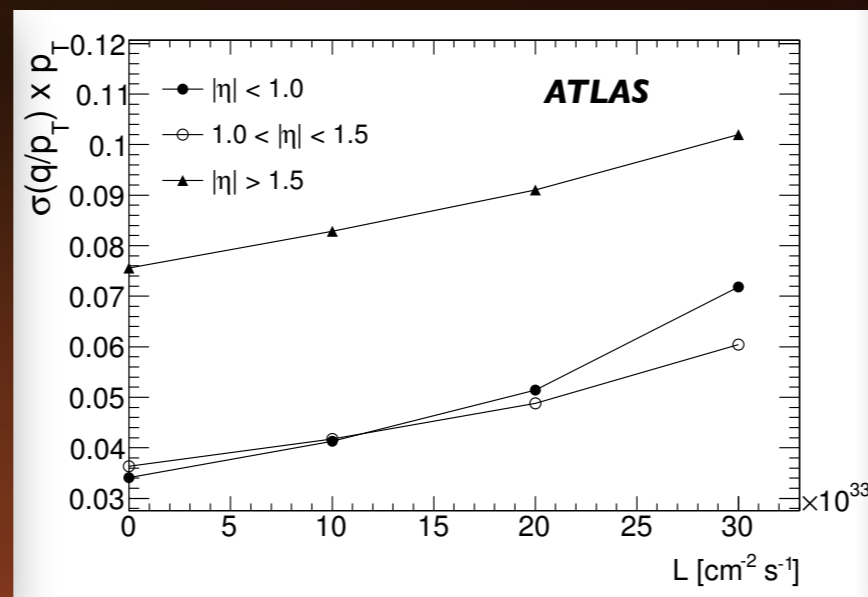
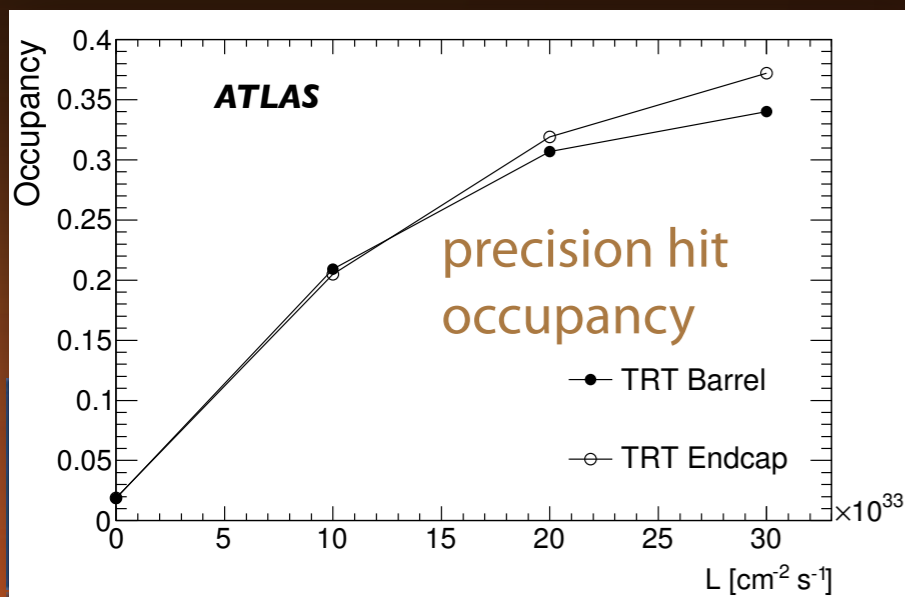
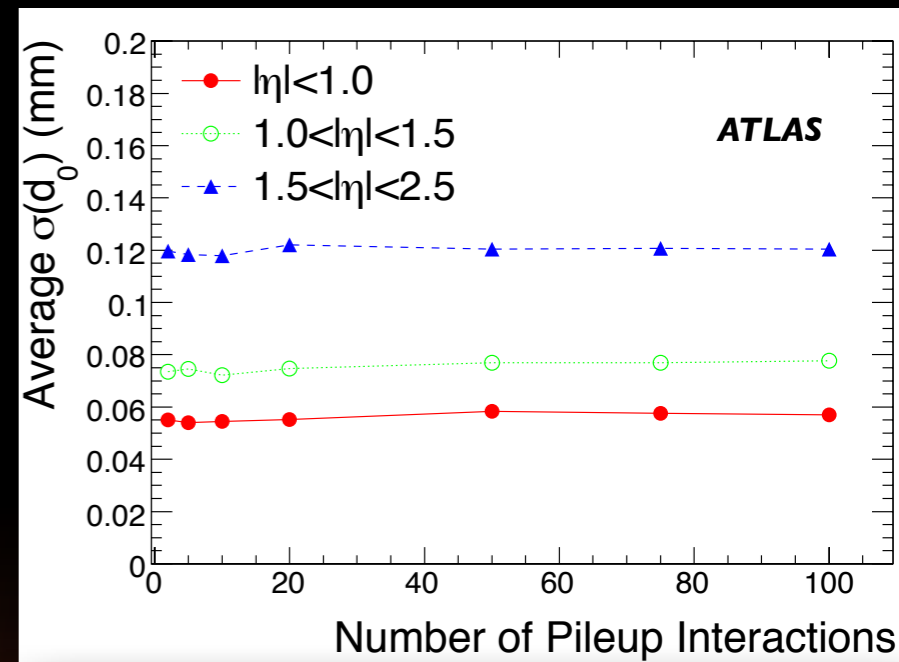
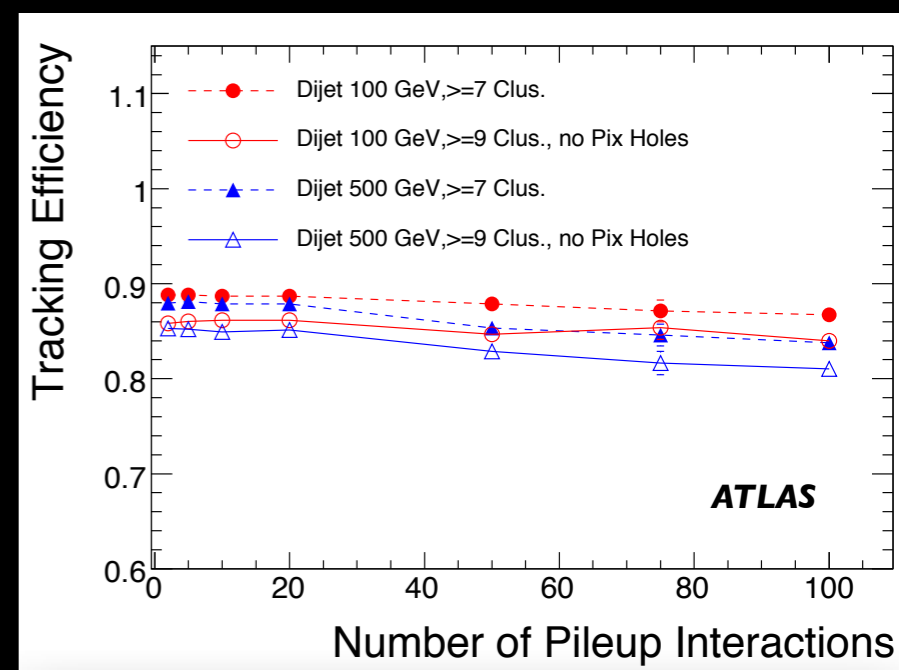

Material Budget limits Performance !

- tracking resolution and efficiency mostly driven by interactions in detector material

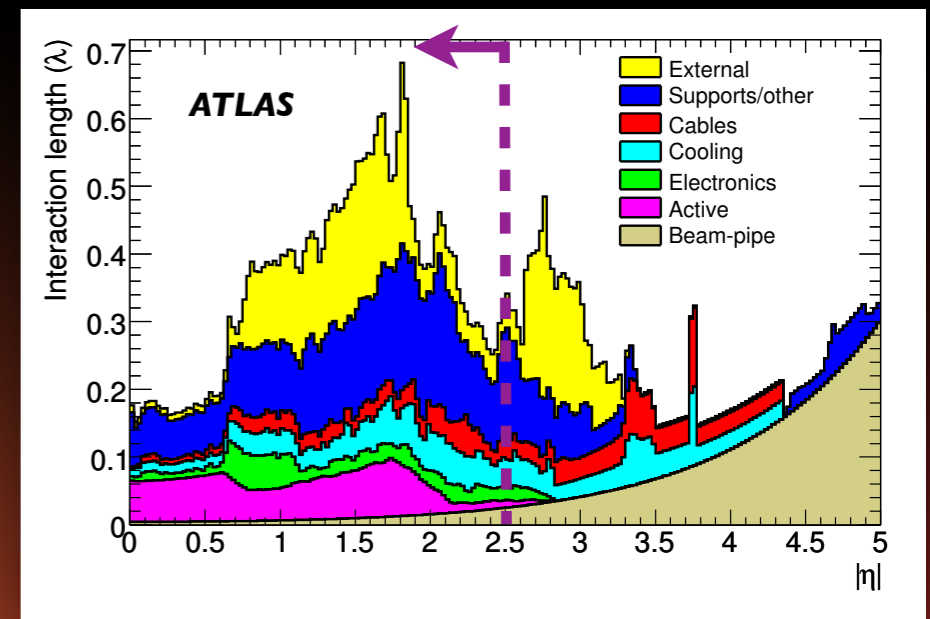
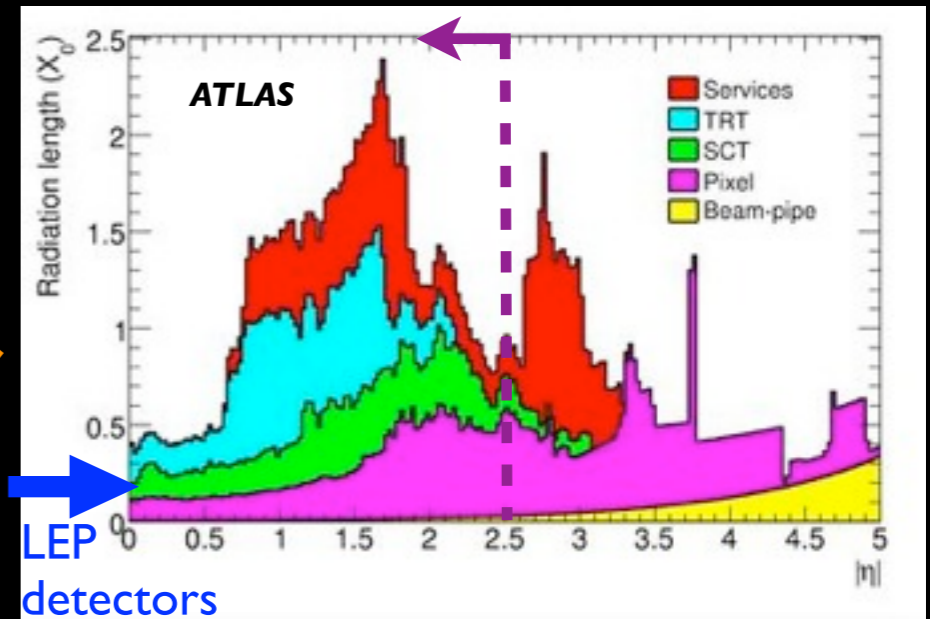
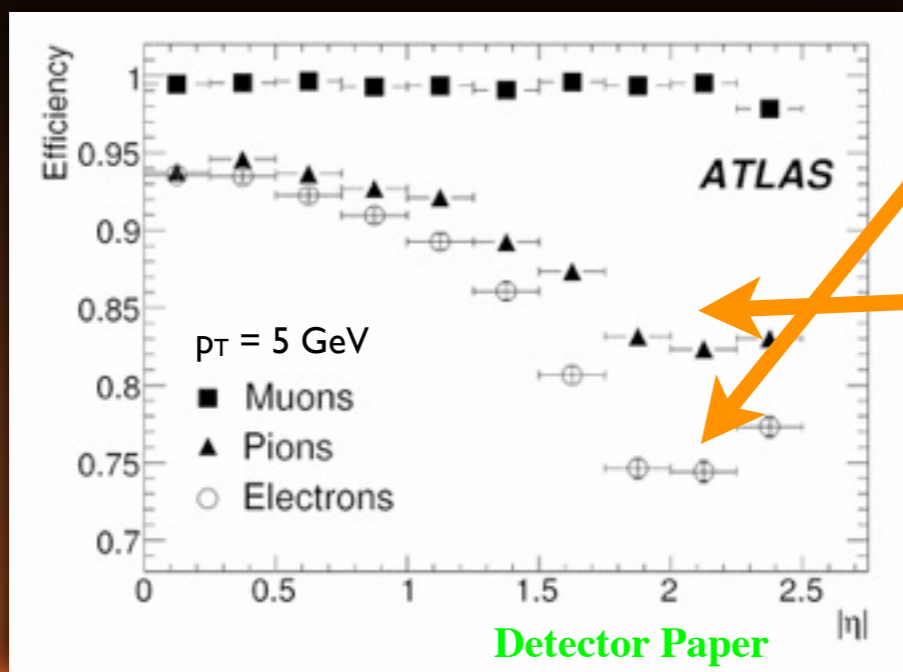
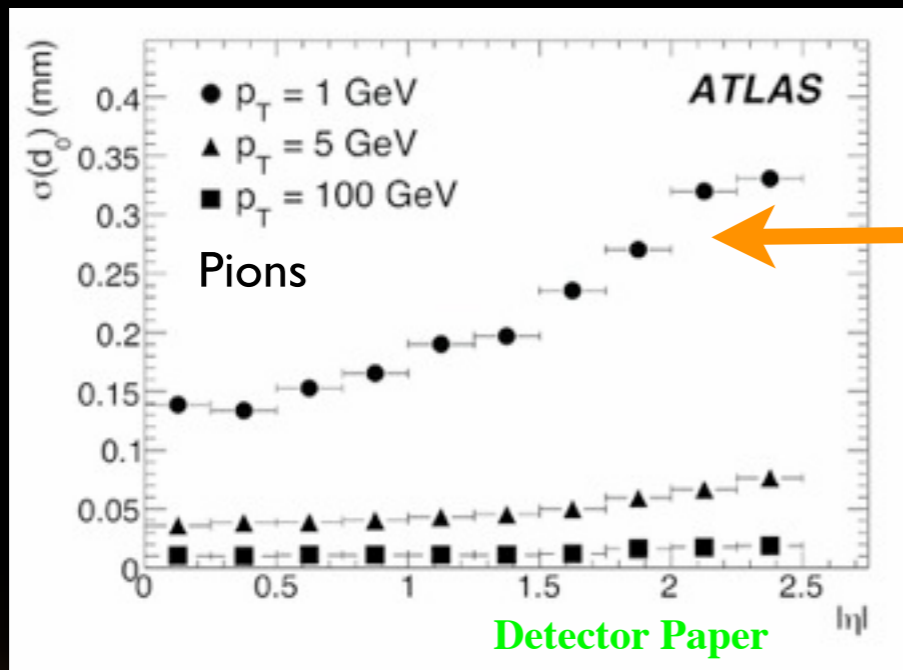

multiple scattering

Bremsstrahlung

hadronic interactions

→ total weight of Inner Detector: 4.5 tons



Weighing Detectors during Construction

- huge effort in experiments
 - ➔ put each individual detector part on balance and compare with model
 - ➔ measured weight of their tracker and its components
 - ➔ correct the geometry implementation in simulation and reconstruction

ATLAS	estimated from measurements	simulation
Pixel package	201 kg	197 kg
SCT detector	672 ± 15 kg	672 kg
TRT detector	2961 ± 14 kg	2962 kg



example: ATLAS TRT
measured before and
after insertion of the SCT

- notice:
 - ➔ significant increase in material budget since Technical Proposal
(we see a similar trend with IBL now)

Date	ATLAS		CMS	
	$\eta \approx 0$	$\eta \approx 1.7$	$\eta \approx 0$	$\eta \approx 1.7$
1994 (Technical Proposals)	0.20	0.70	0.15	0.60
1997 (Technical Design Reports)	0.25	1.50	0.25	0.85
2006 (End of construction)	0.35	1.35	0.35	1.50

Required new Software Technologies

- complex G4 geometries not optimal for reconstruction
 - ➔ simplified **tracking geometries**
- reduced number of volumes
 - ➔ blending details of material

	G4	tracking
ATLAS	4.8 M	10.2K *

*2 plus a surface per Si sensor

- ➔ use embedded navigation scheme to optimize CPU performance

ATLAS	G4	tracking	ratio
crossed volumes in tracker	474	95	5
time in SI2K sec	19.1	2.3	8.4

(neutral geantinos, no field lookups)

- ➔ as well basis of fast simulation engine

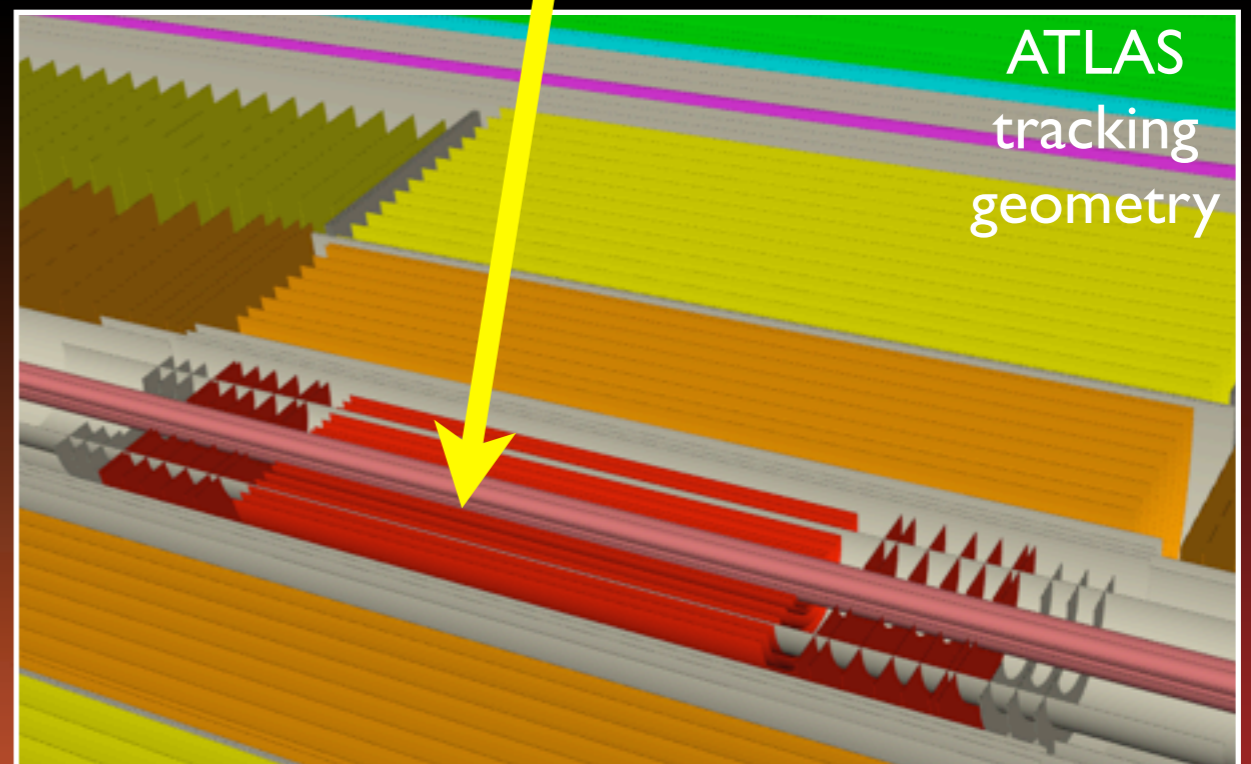
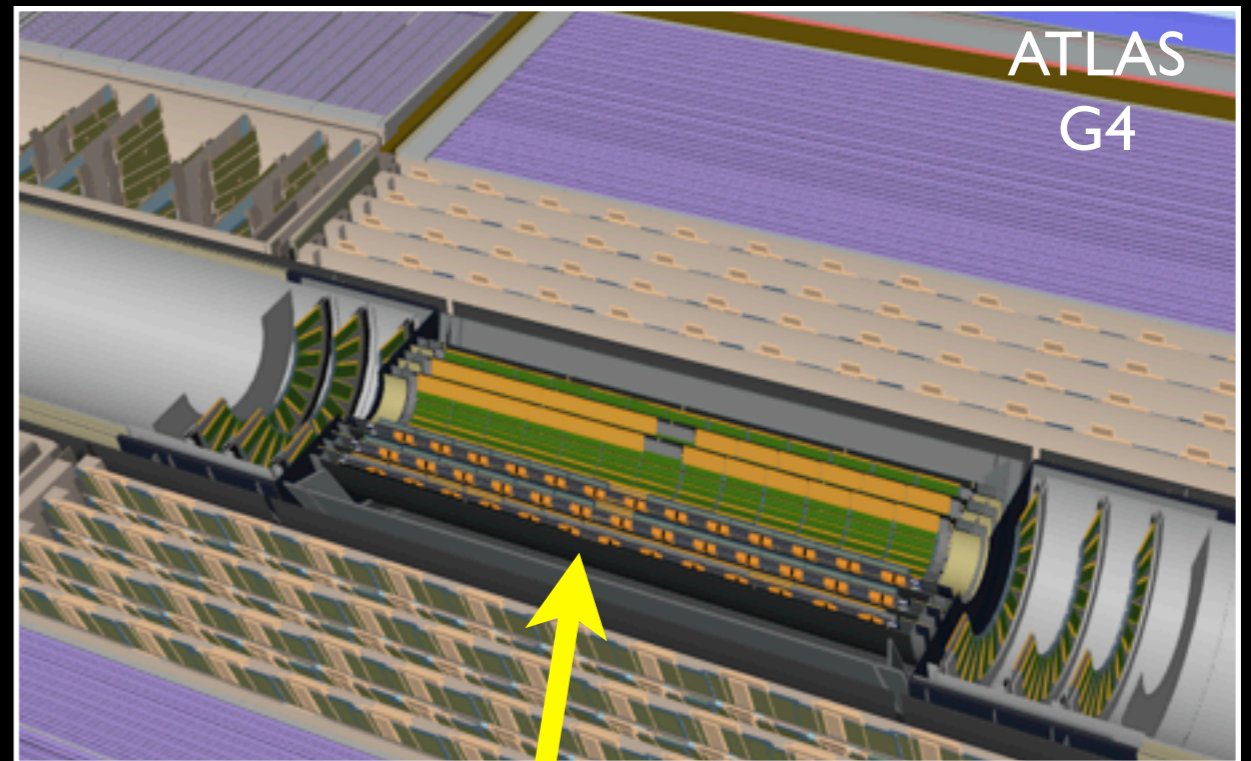

Alignment and Weak Modes

- global- χ^2 alignment
 - ➔ diagonalize alignment matrix $(6 \times 6k)^2$
 - ➔ enables studies of Eigenvalue spectrum
 - well constraint : local movements
 - less well constraint : overall deformations
 - not constraint : global transform

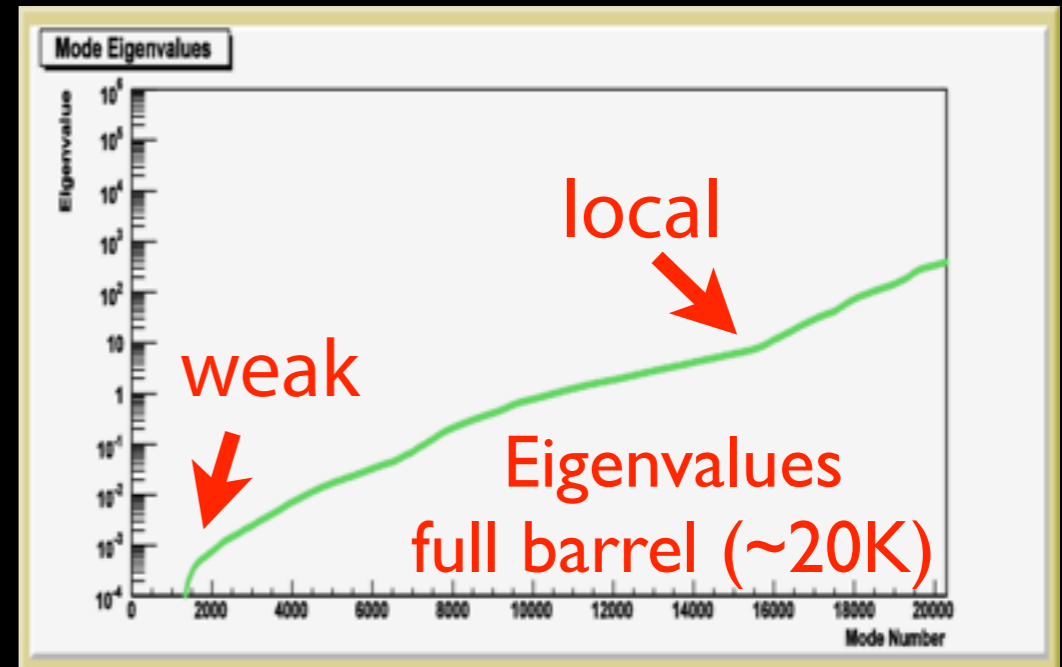

- residuals relevant for b-tagging
 - ➔ mostly sensitive to local movements track
 - ➔ well constraint by module overlaps and beam spot constraint

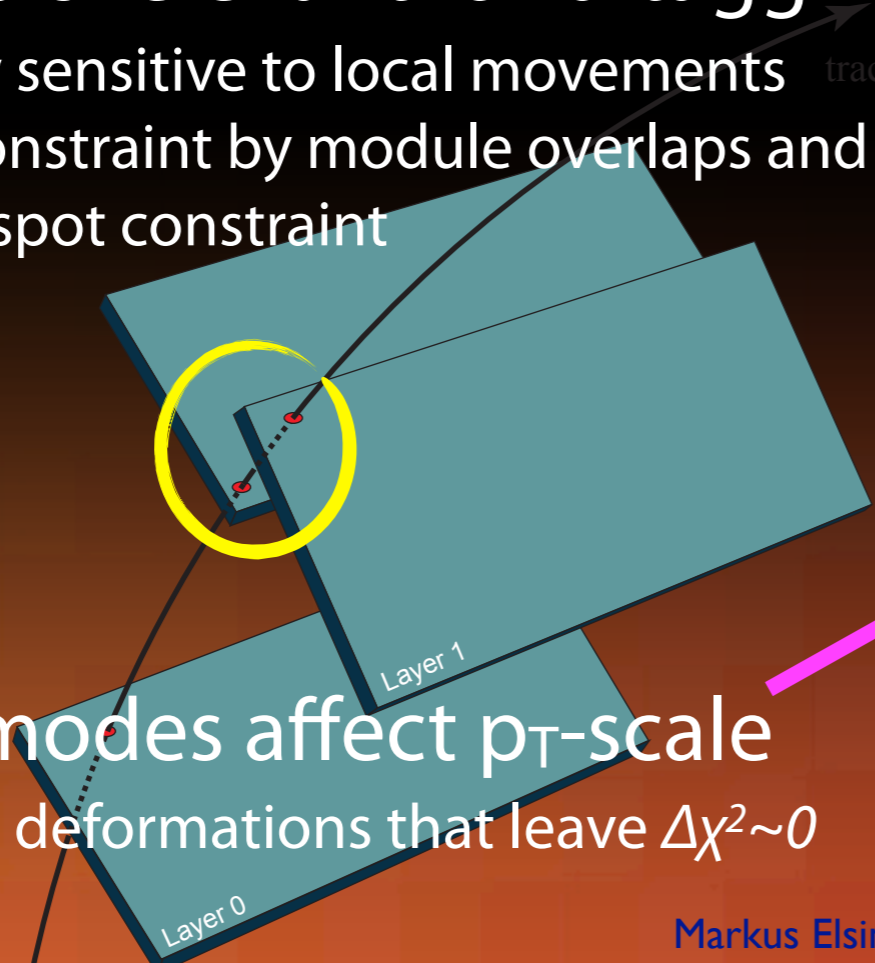

- weak modes affect p_T -scale
 - ➔ overall deformations that leave $\Delta\chi^2 \sim 0$

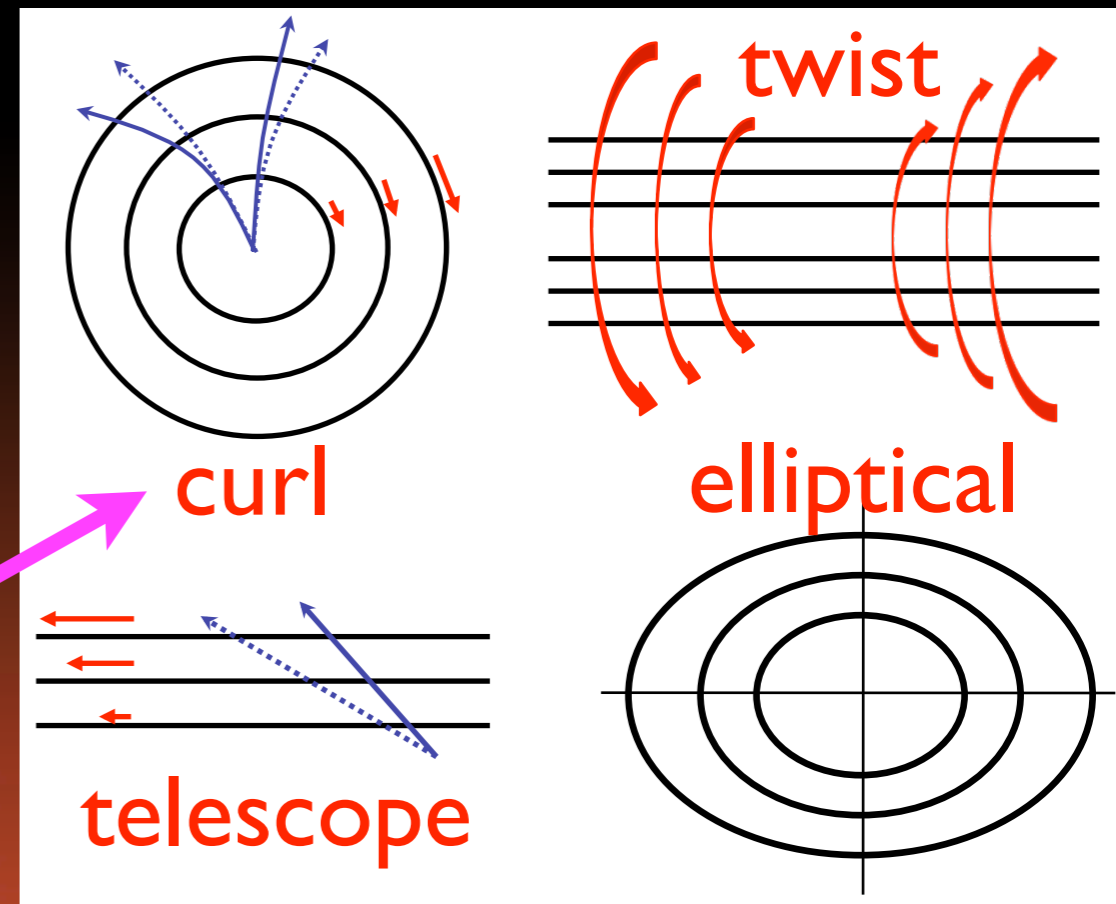

Did we expect Weak Mode Effects ?

- “Detector Paper” MC study:
 - ➔ ideal Z mass resolution 2.6 GeV
 - ➔ misalign MC by 100 μm , re-align using:
 - high- p_T muons and cosmics
 - ➔ Z mass resolution degraded to 3.9 GeV (!)
 - not corrected by alignment procedure
- cosmics study using split tracks
 - ➔ good performance overall
 - cosmics are mostly in the barrel (!)
 - done with the alignment at the time...
 - ➔ but: at higher p_T the data starts to diverge from MC
 - reflects limited calibration at the time
 - possible hint for weak mode effect in alignment

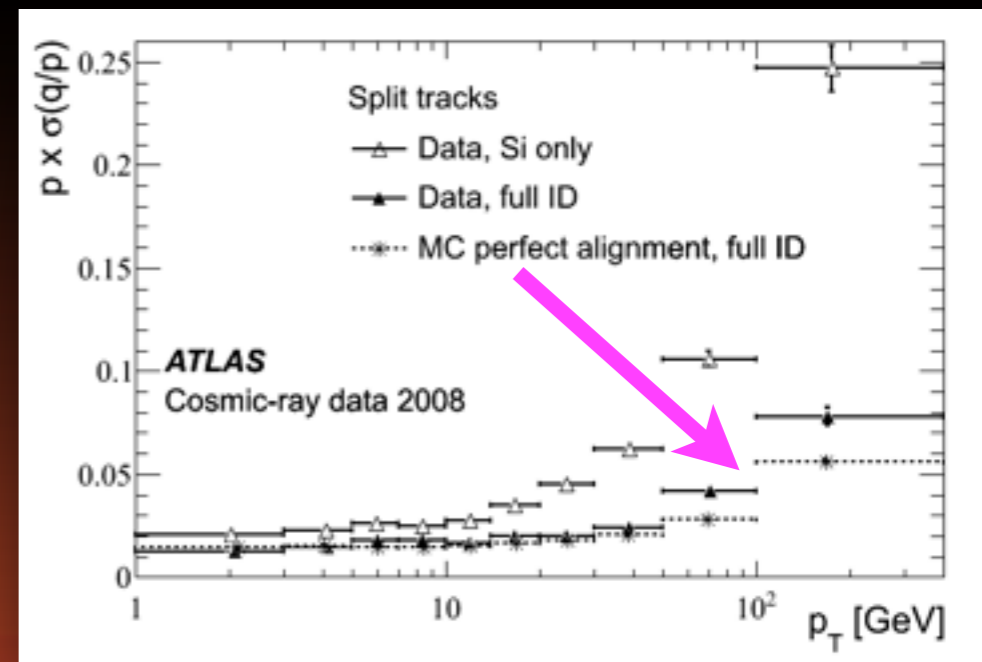
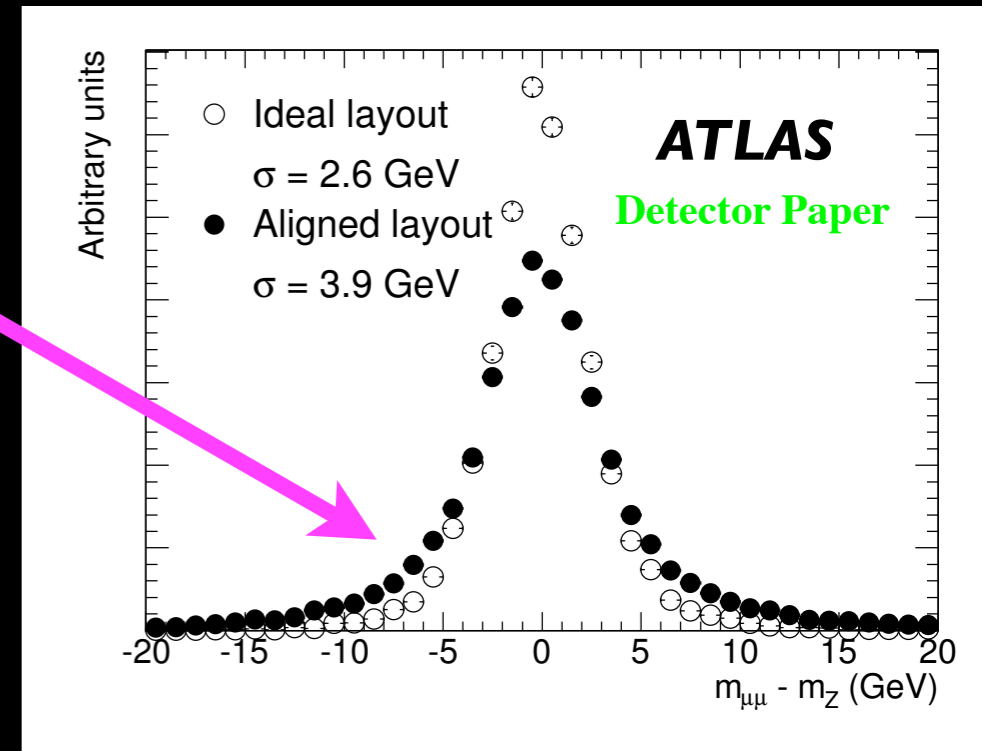

Excitement with first beams...



Commissioning with Collision Data

- LHC has done fantastic since !
- a long way from first collisions to physics
 - ➔ commission full readout chain (detector, trigger, DAQ)
 - ➔ calibrate and align the detector
 - ➔ optimize the tracking performance, allow for changing levels of pileup
 - ➔ ...
- basis of commissioning the tracking is work done on the detector !
 - ➔ not be able here to do justice to all aspects of detector calibration...

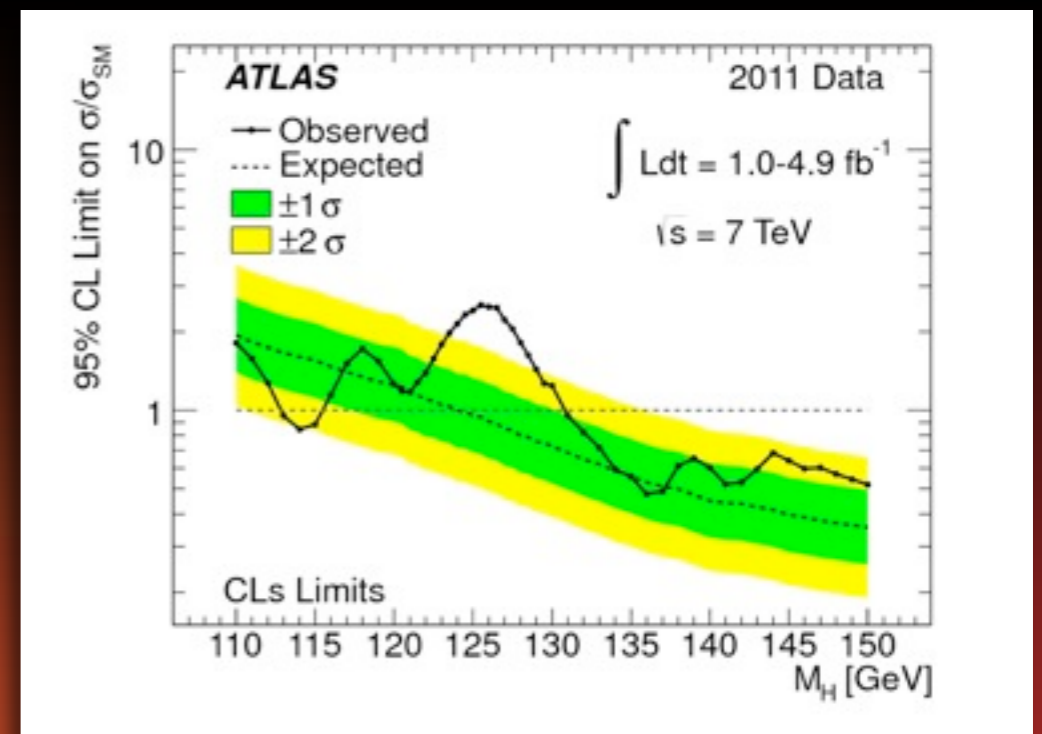
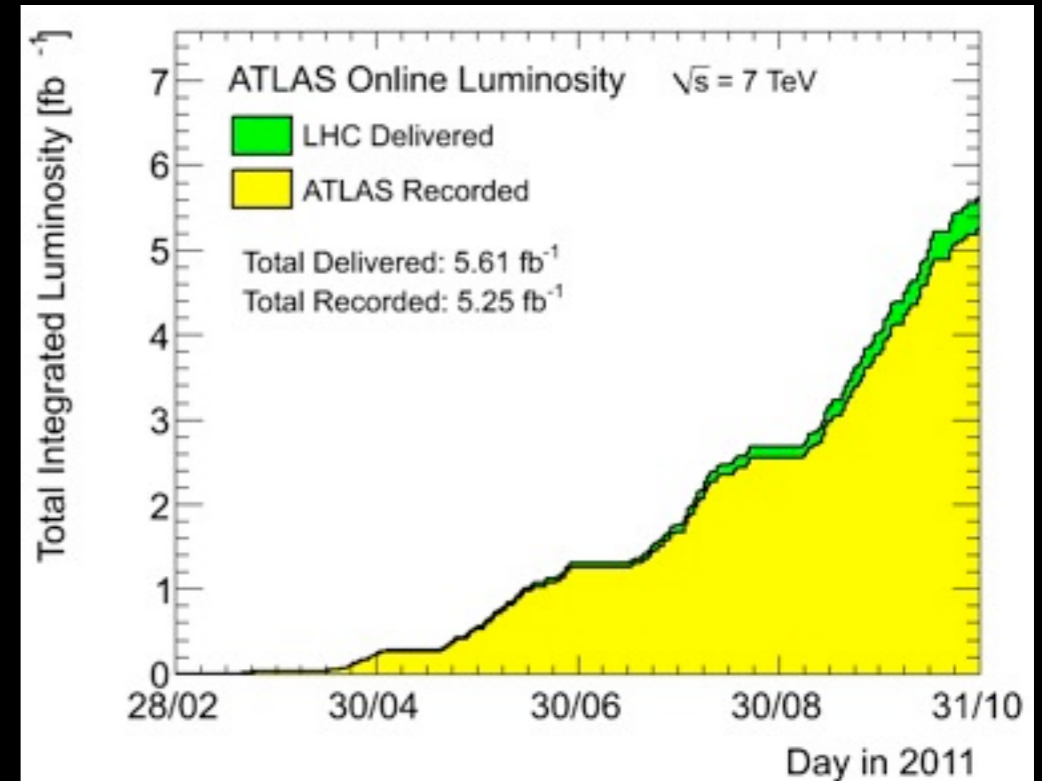

Detector Calibration

- careful calibration of detectors

- required to reach design performance
- online (thresholds,...) and offline
- monitoring of variations with time

- examples:

- TRT: R-t relation and high threshold probability
- calibration of time over threshold in Pixels
 - required to explore power of analog clustering
 - provide dE/dx for low p_T particles as well

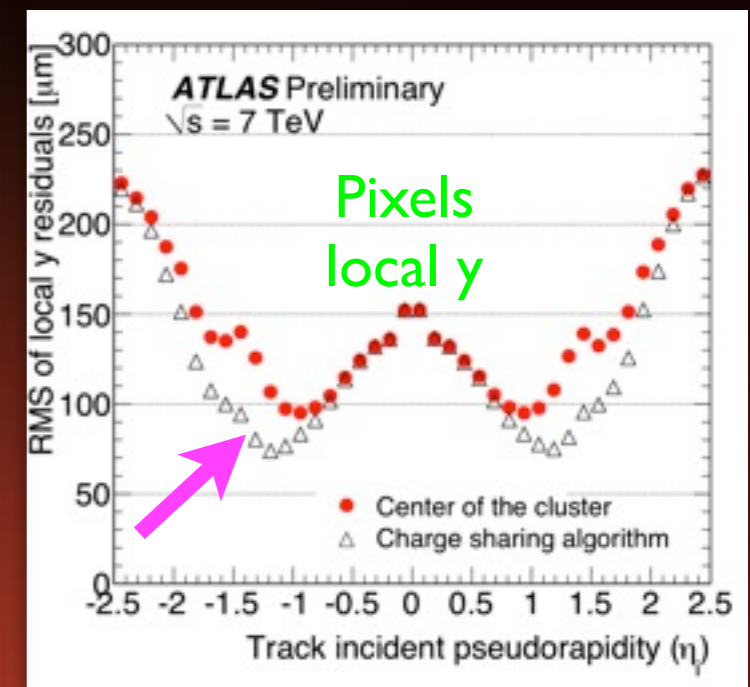
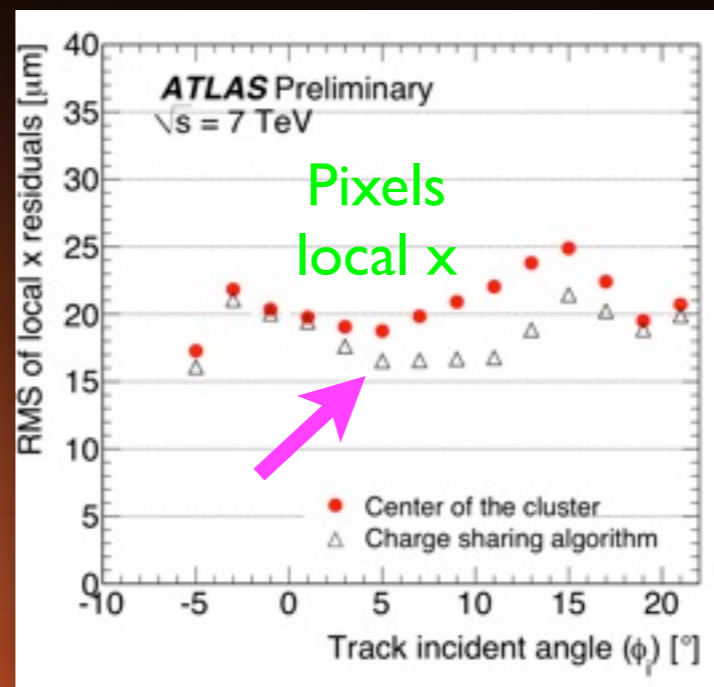
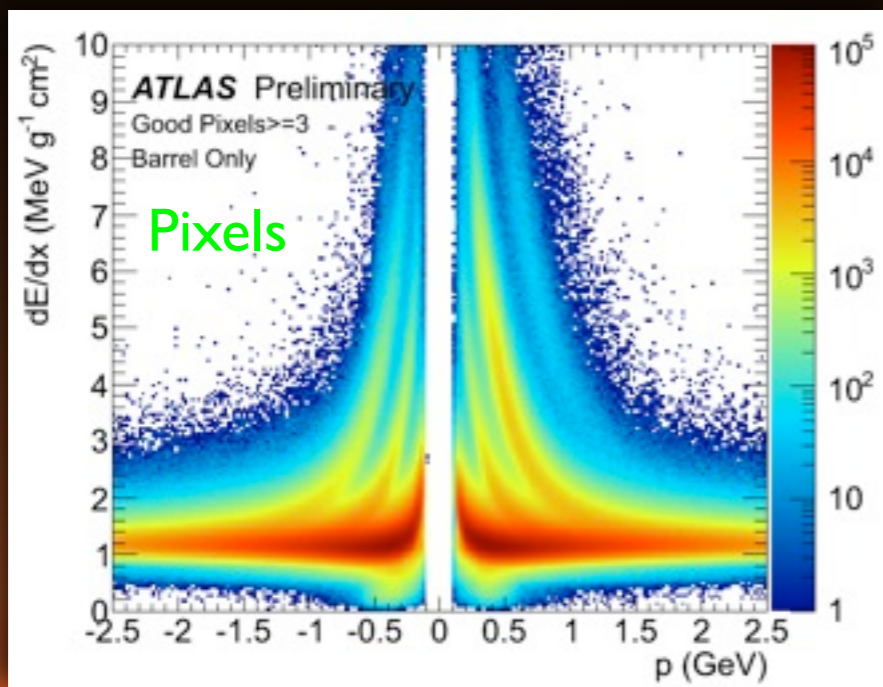
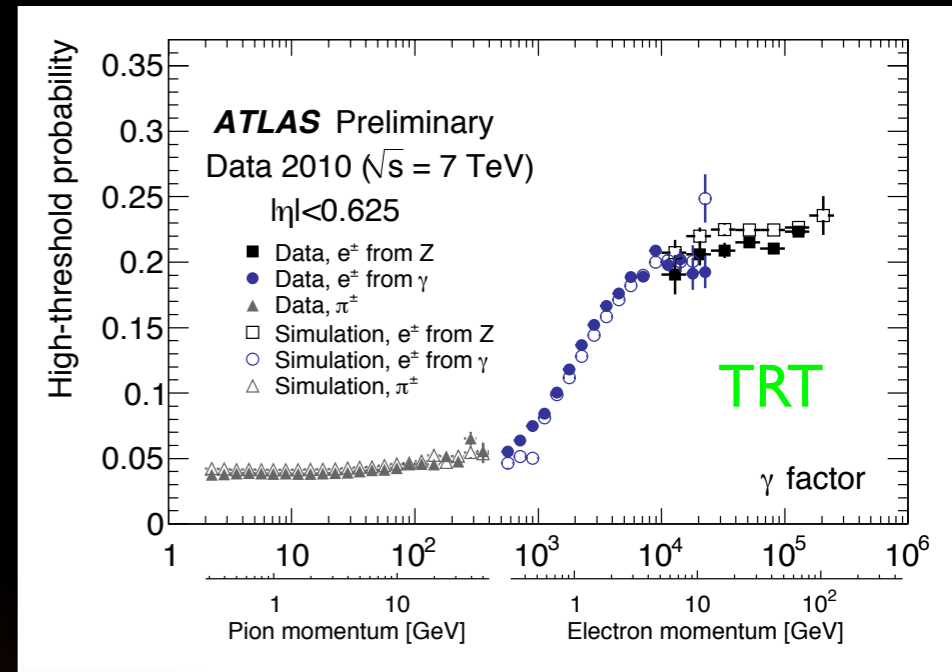
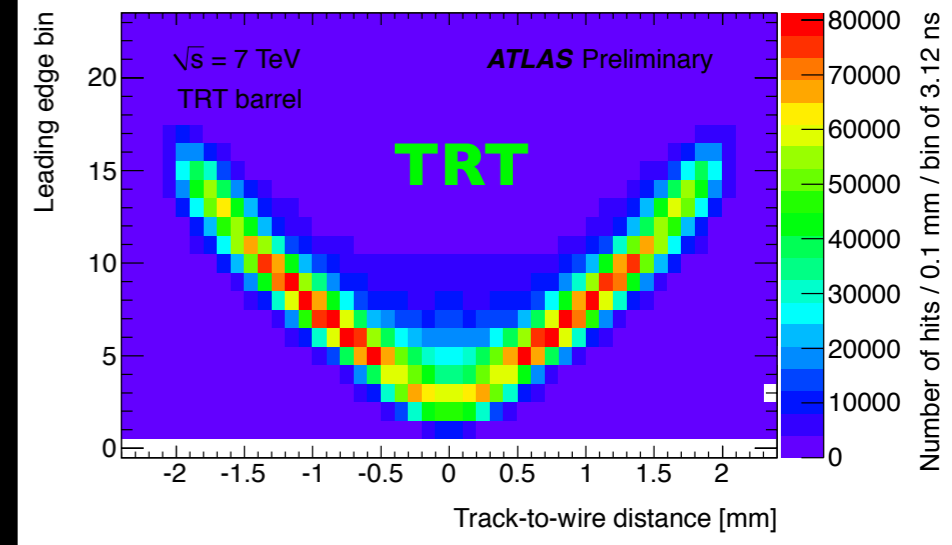

Detector Calibration

- study detector efficiencies
 - ➔ identify dead channels, chips, modules
 - typically $\geq 97\%$ of detectors are operational
 - after correction for known defects typical sensor efficiencies are $>99\%$ (!)
 - ➔ very low noise levels observed in Pixels/SCT
- measure Lorentz angle
 - ➔ as usual study cluster sizes vs track incident angle
 - ➔ input to tuning of cluster properties
 - adjusting digitization parameters to match data

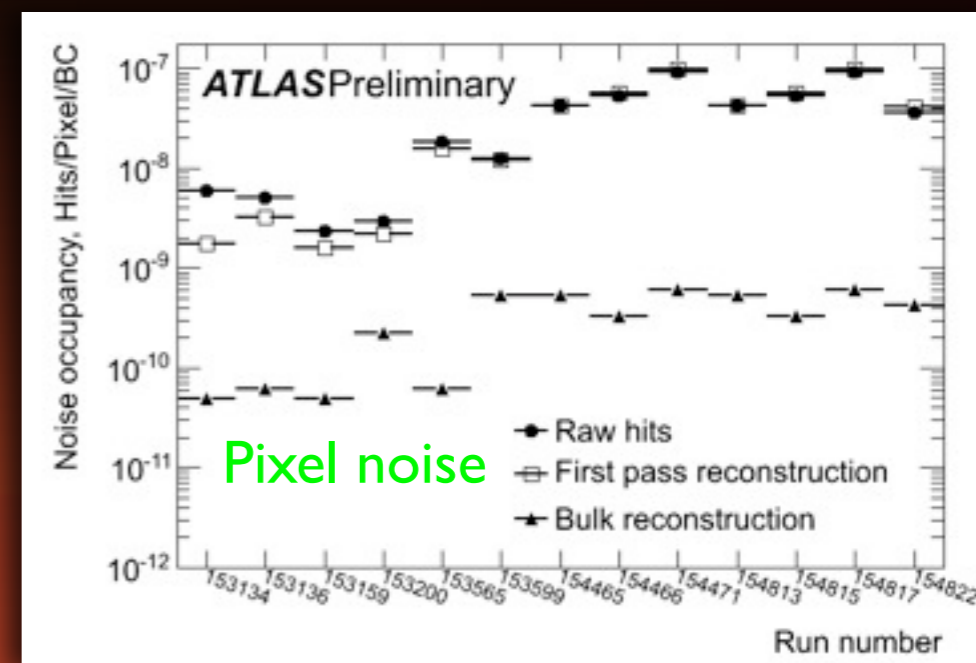
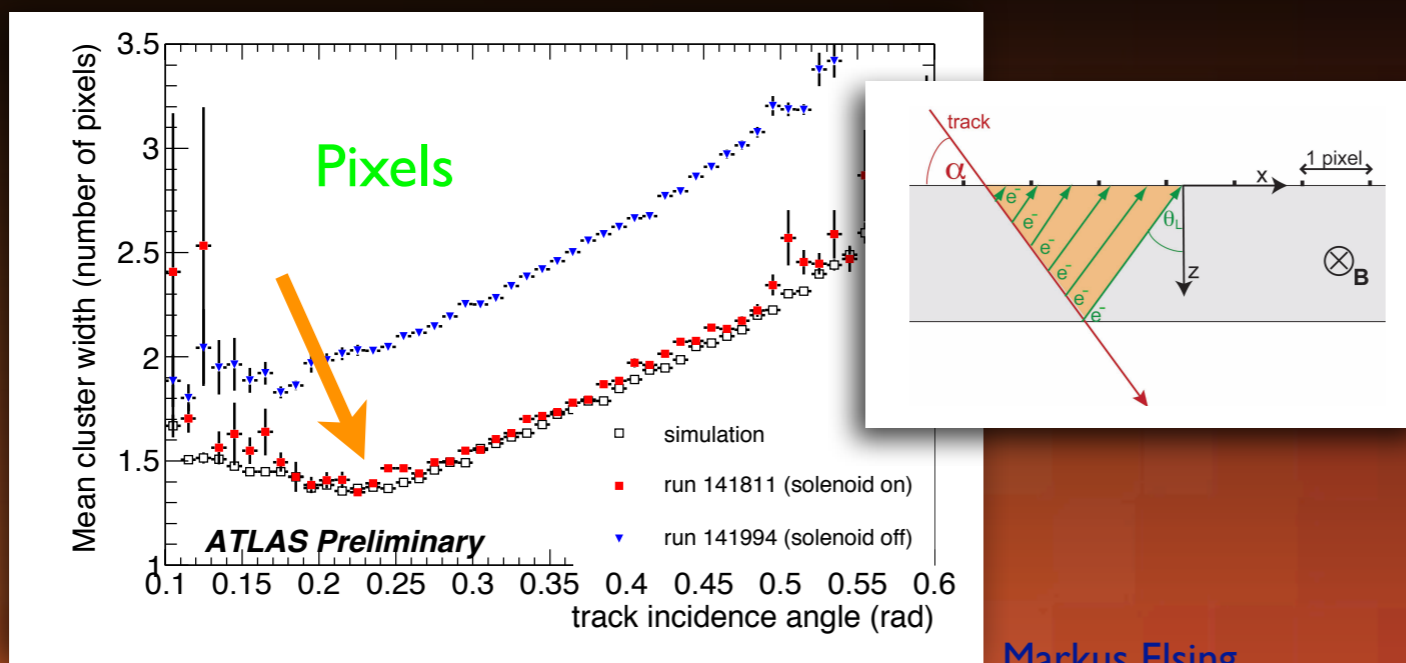
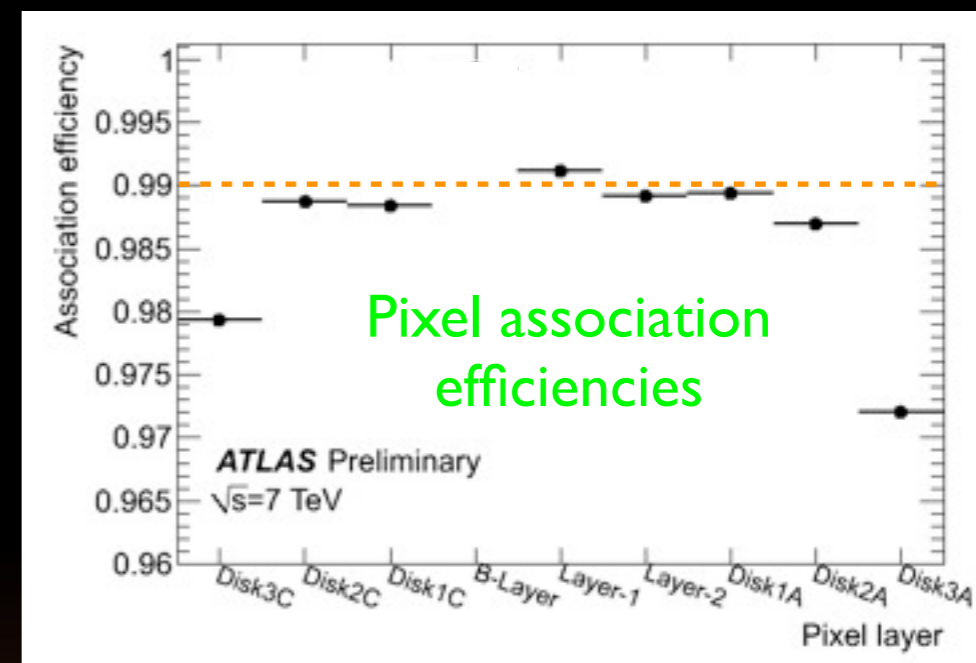
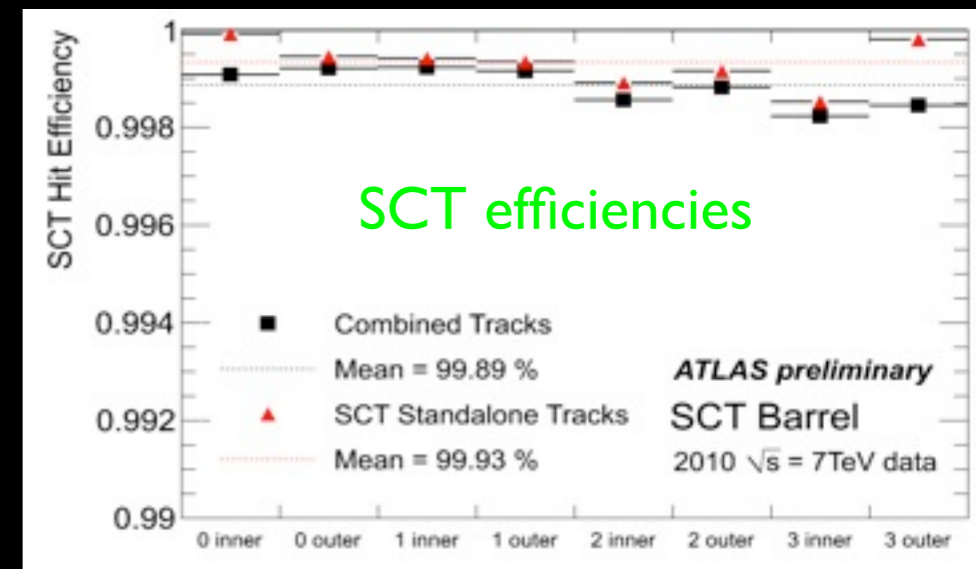

Tracking Commissioning

- detailed studies of properties of tracks in 900 GeV data
 - ➔ hit associations, fit quality, etc.
 - allow for known defects in simulation
 - ➔ leading towards first publications
 - as expected, tracking systematics driven by material uncertainties (!!)

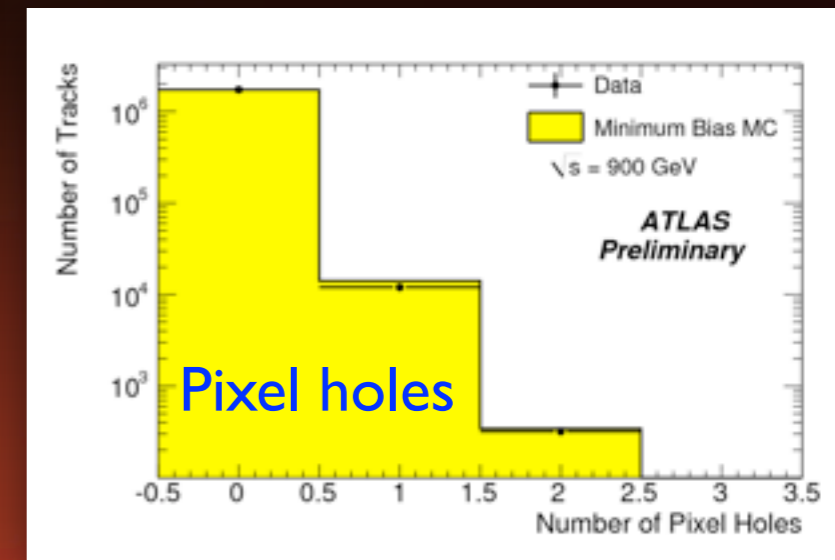
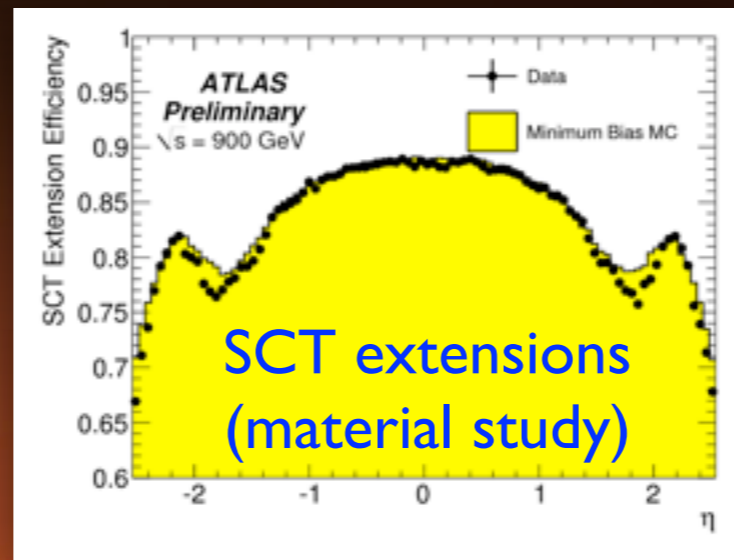
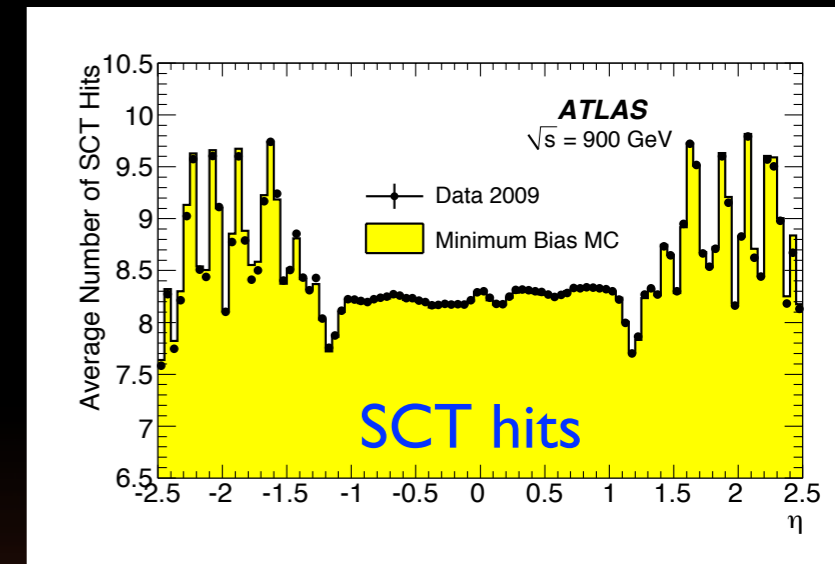
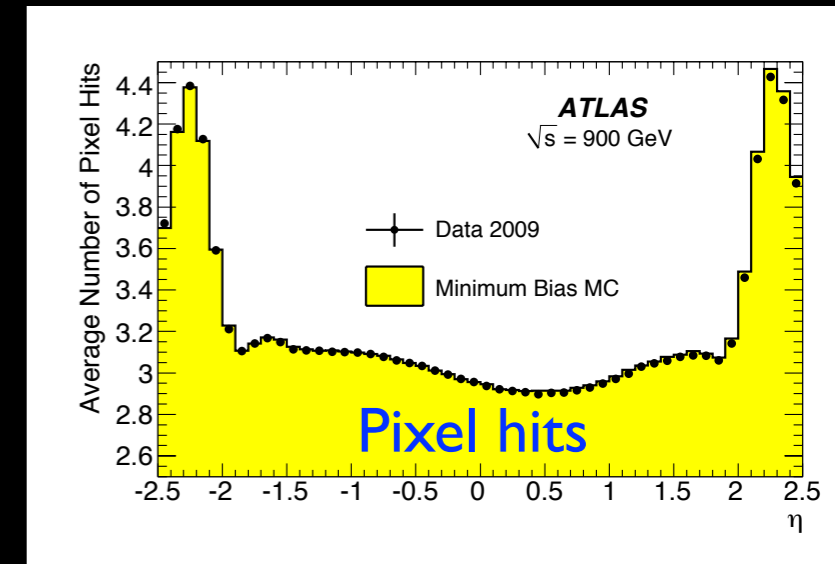

min.bias charged particle spectra

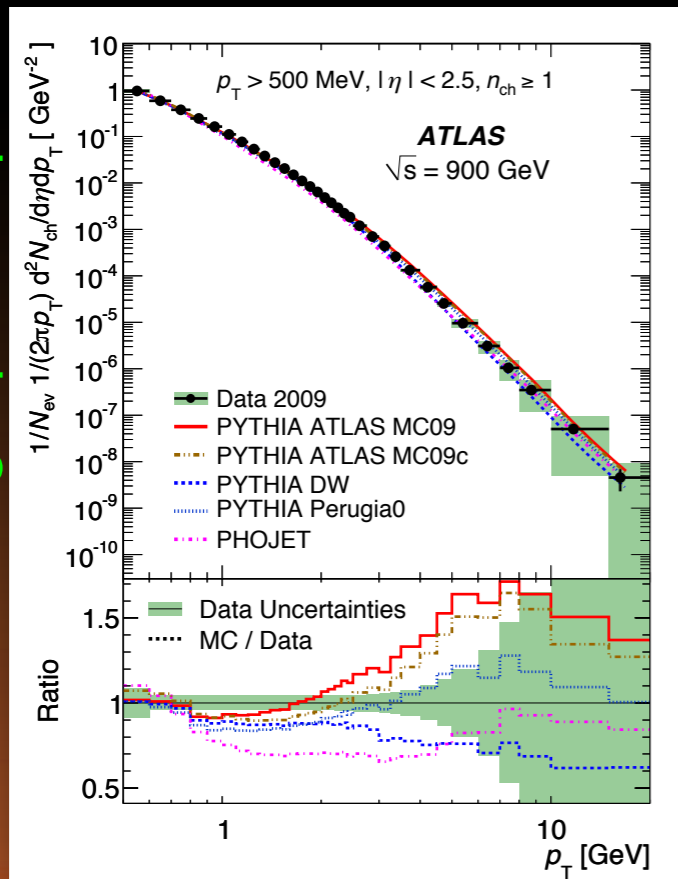

Conversions

- detailed tomography of material with γ conversions
 - ➔ able to map details in material distribution
 - measure difference in data/MC, e.g. PP0
 - ➔ ultimately should result in a very precise estimate of material
 - need to control reconstruction efficiency
 - calibrate measurement, e.g. on “known” beam pipe
 - needs a large dataset to reach precision

ATLAS
Pixel
PP0
region

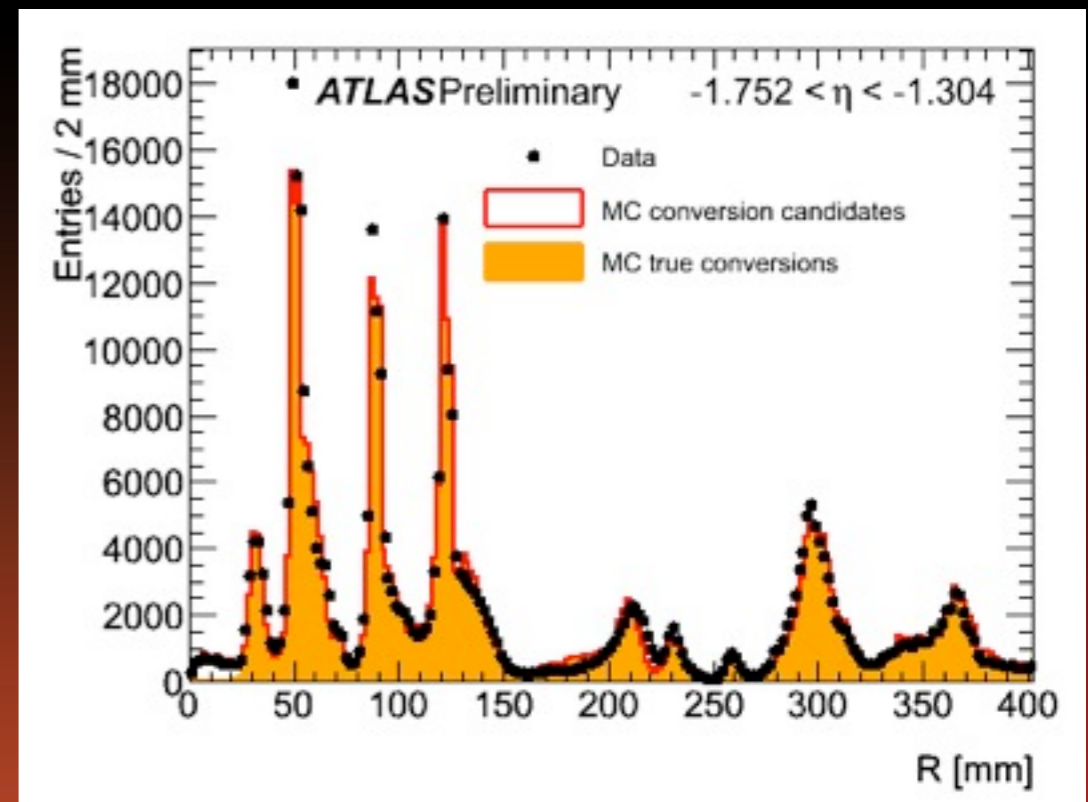
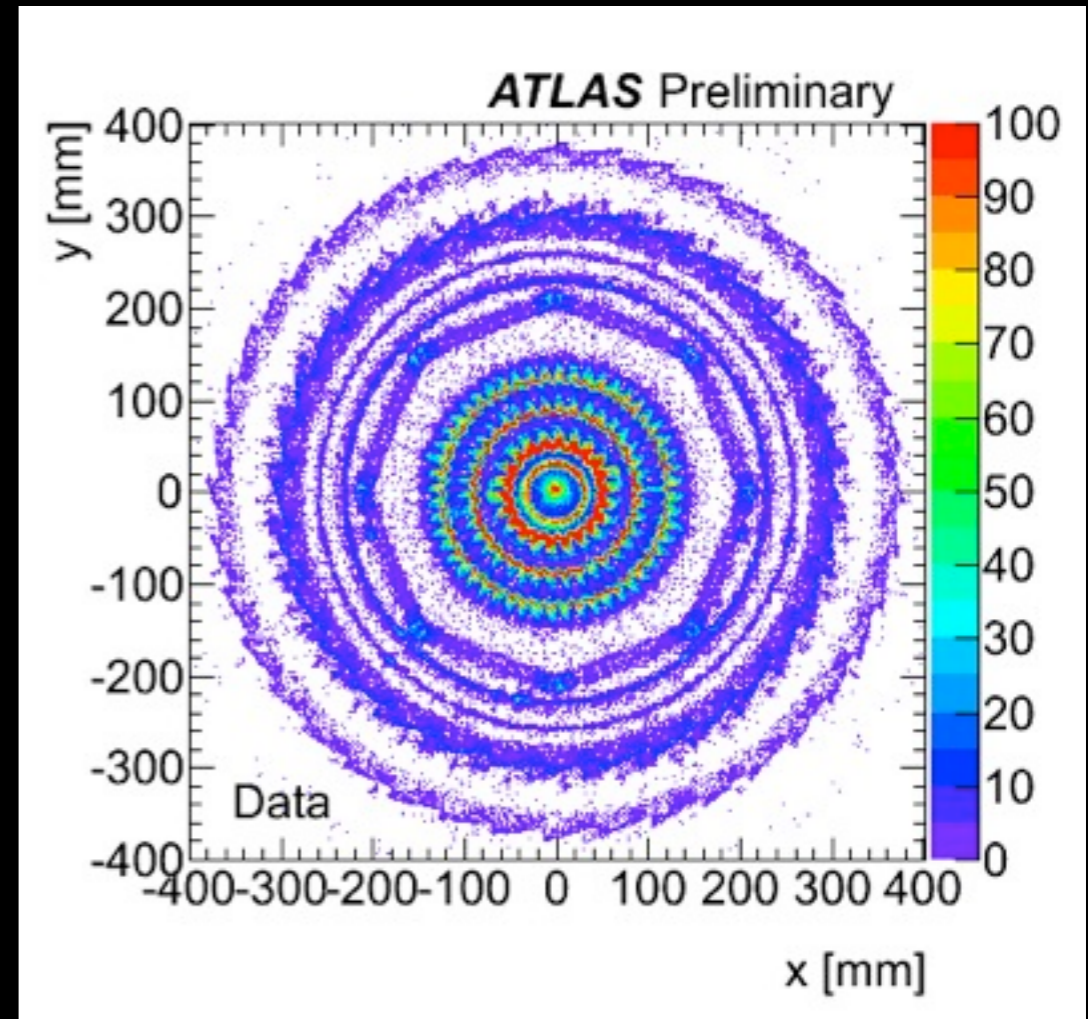
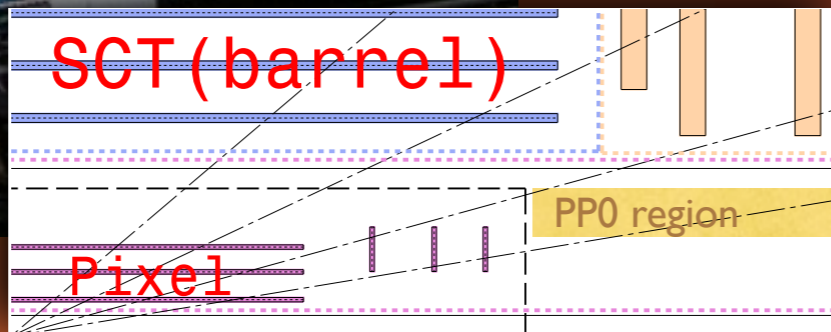
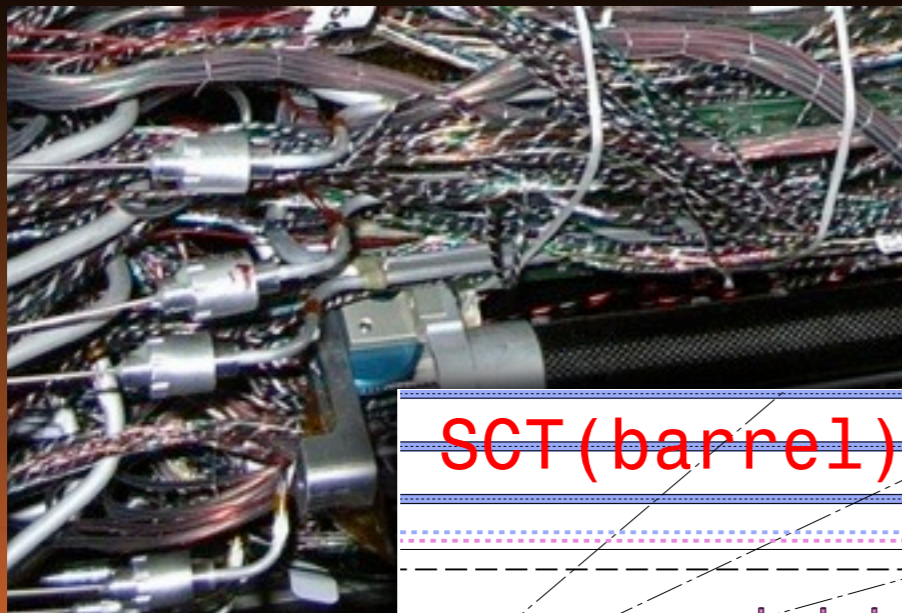

Further Material Studies

- hadronic interactions for precise tomography of detector material
 - ➔ good vtx resolution allows to study fine details
 - ➔ e.g., study levels of cooling liquid or shift in beam pipe position w.r.t. Pixel b-layer
- material uncertainty in simulation
 - ➔ constraint by sum of different techniques
 - conversions and hadronic interactions
 - study K^0_s and other mass signals
 - stopping tracks, SCT extension efficiency
 - study of multiple scattering resolution term
 - ➔ estimated uncertainty
 - better than **~5%** in central region
 - at the level of **~10%** in most of the endcaps

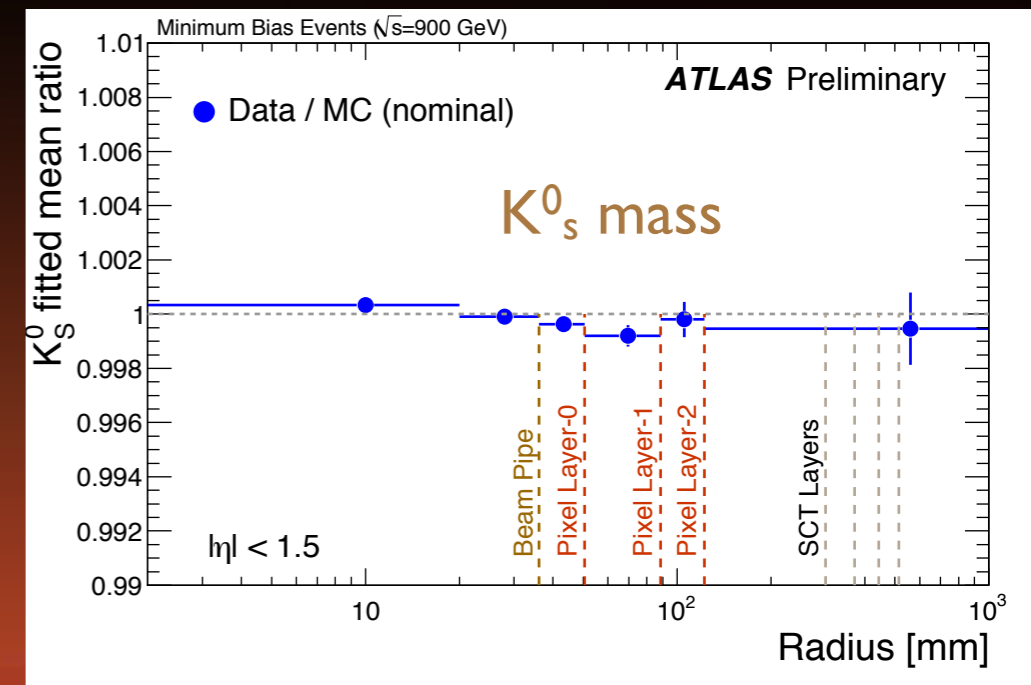
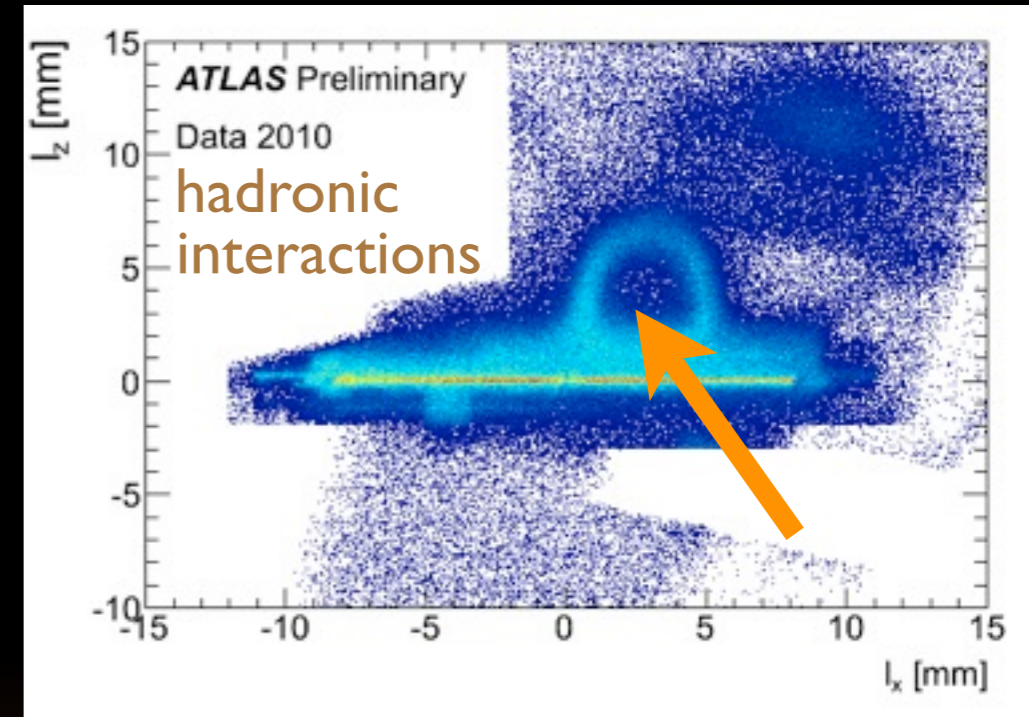
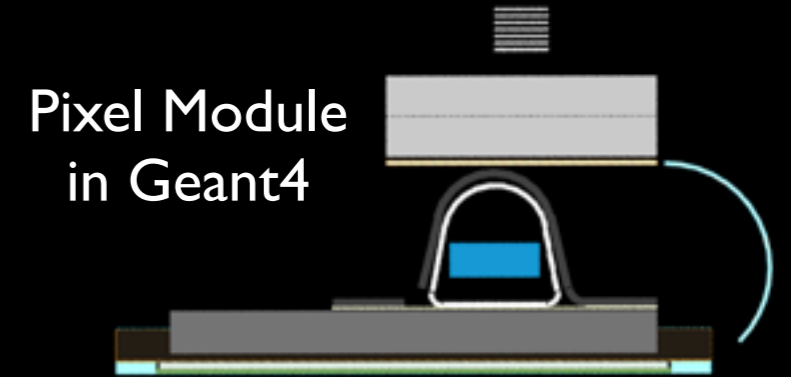

Detector Alignment

- is an art...
 - ➔ plenty of subtle effects to allow for
- Pixel stave bowing
 - ➔ probably mechanical stress from mounting
- TRT wire alignment
 - ➔ twist between 4 plane wheels
 - ➔ traced back to the wheel production
 - ➔ fix with alignment of each wire (!!)
- detector movements
 - ➔ traced back to
 - cooling failures
 - power cuts
 - magnet ramps
 - ➔ level-1 movements of $\sim 5\mu\text{m}$ (mostly)

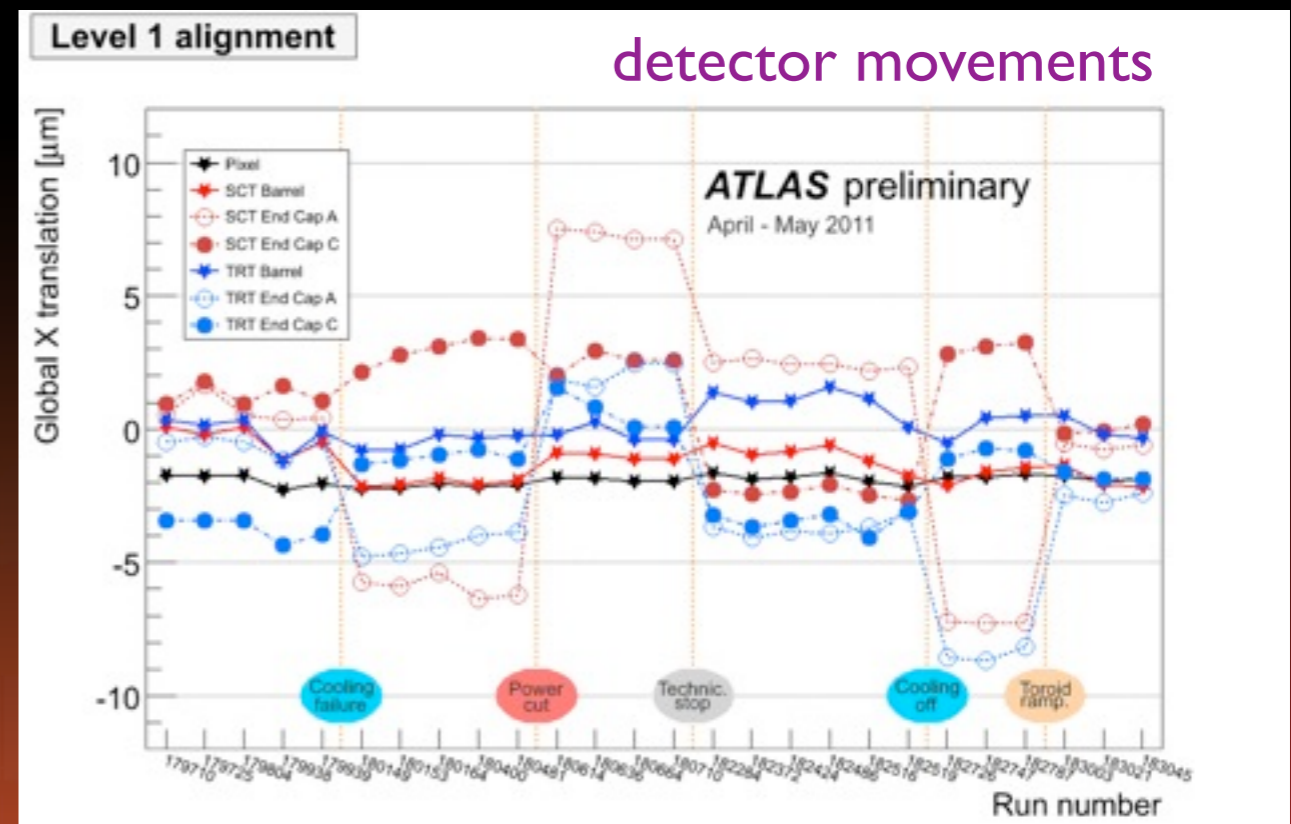
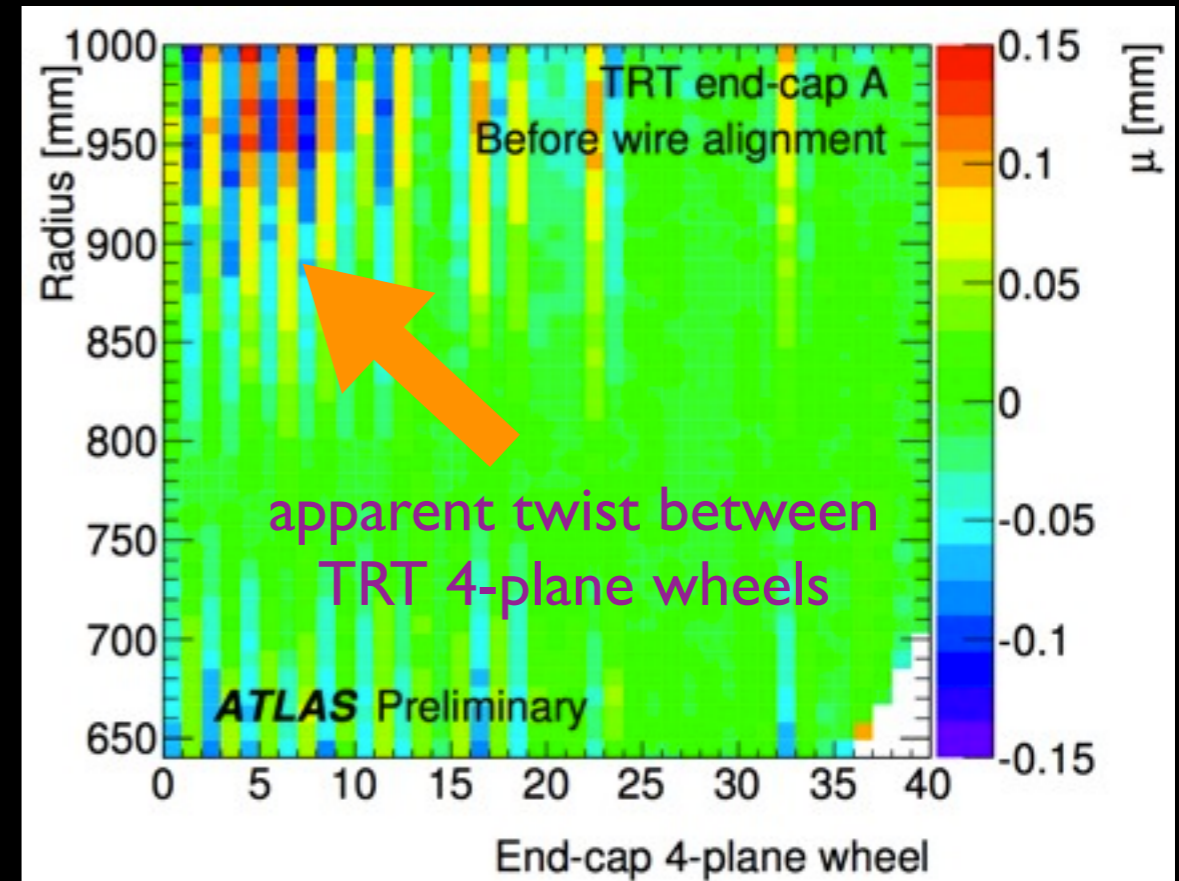

Pixel Module Distortions

- survey told us Pixel modules are not flat

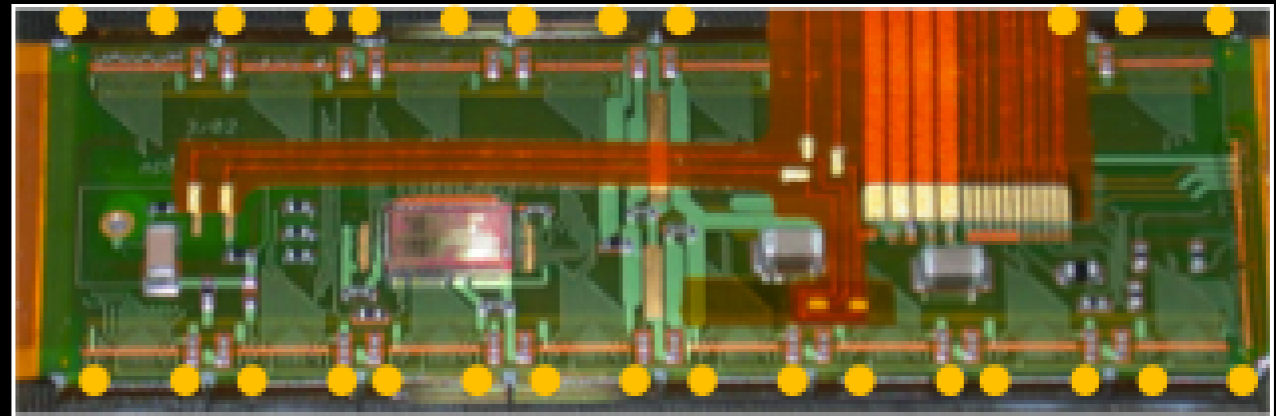
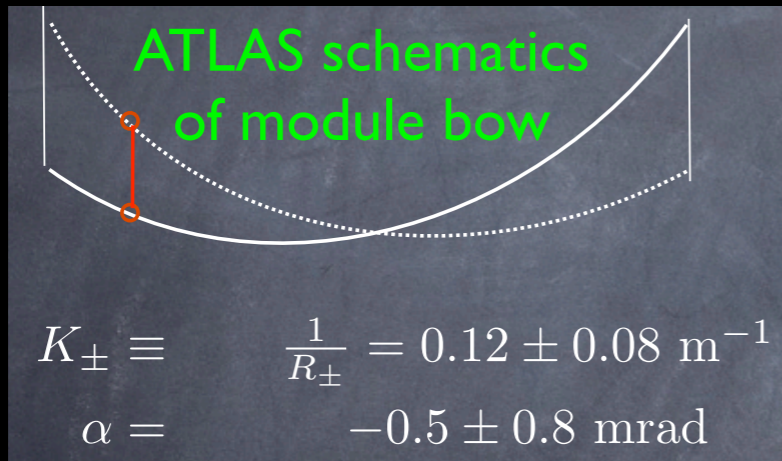

survey points



- correct cluster positions for module shape

➔ significant improvement in resolution (SCT bow is small, current not corrected)

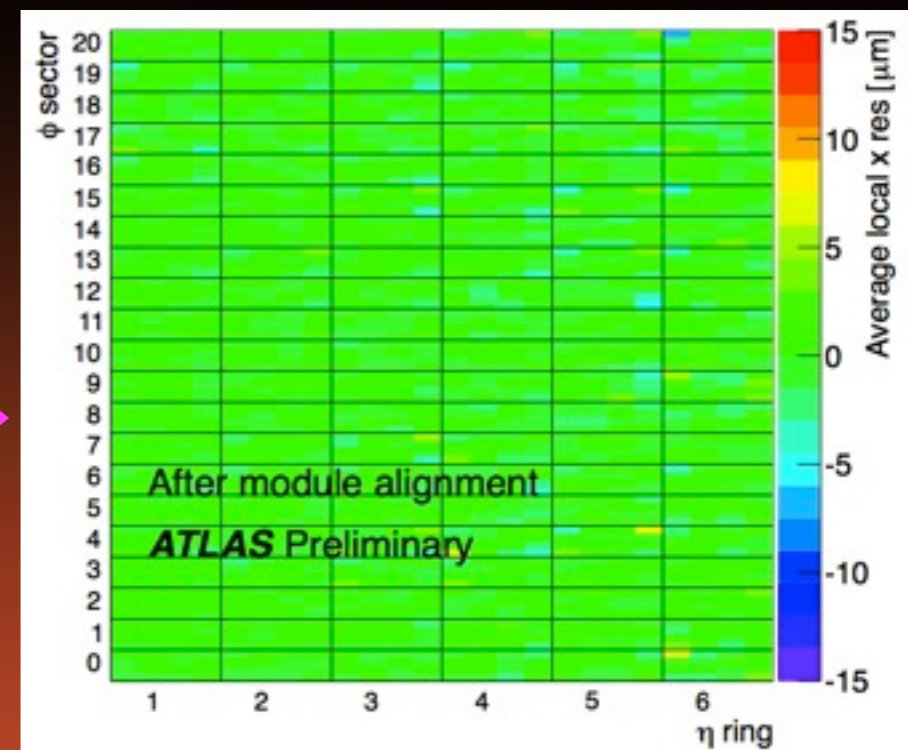
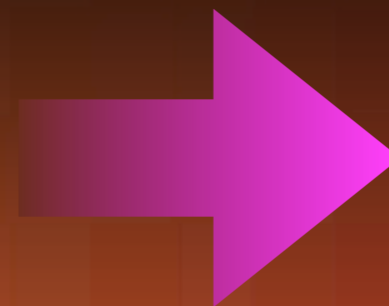
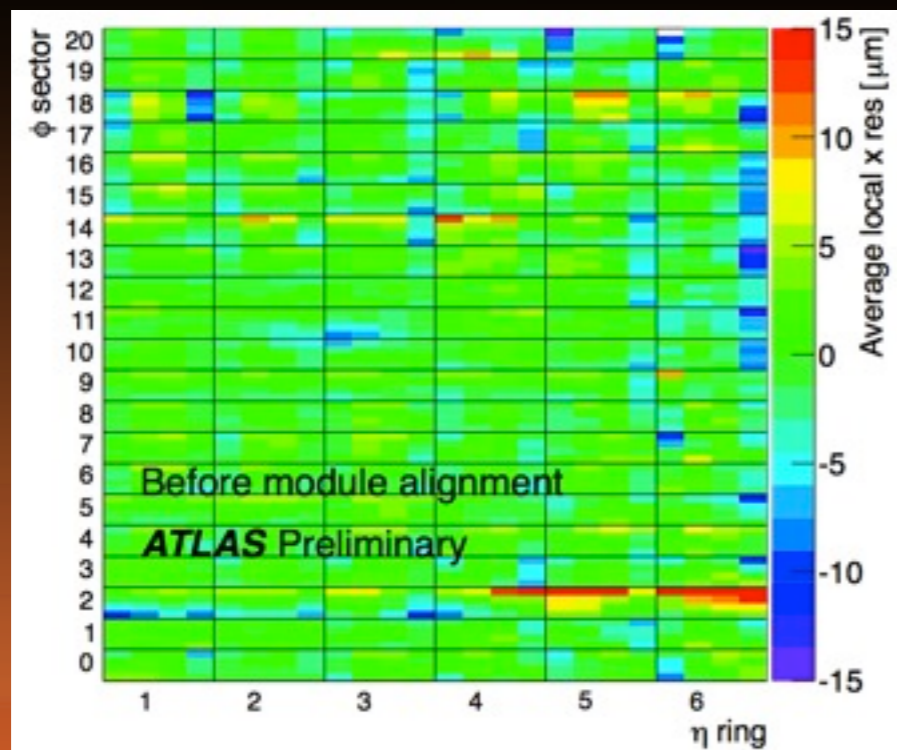

Residuals and Impact Resolution

- driven by local misalignments
 - ➔ quickly approaching design resolutions
 - ➔ some small problems still visible
 - hence apply some error scaling in fit
 - ➔ material dominates at low p_T

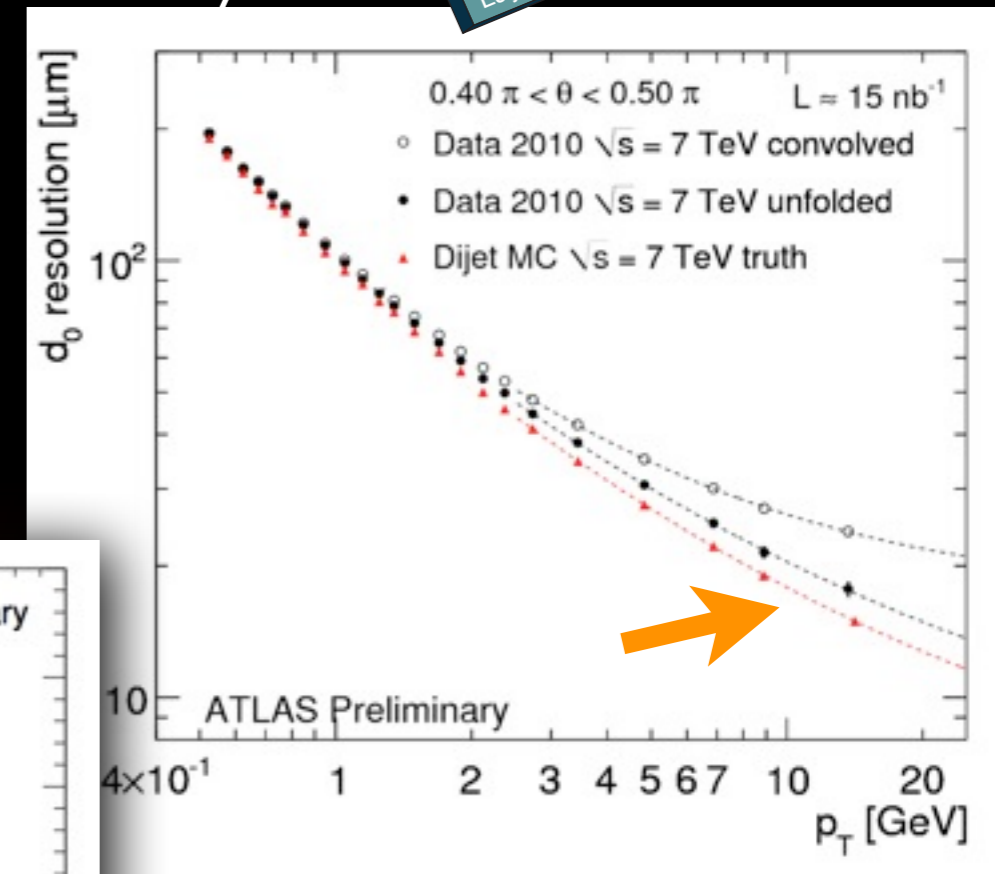
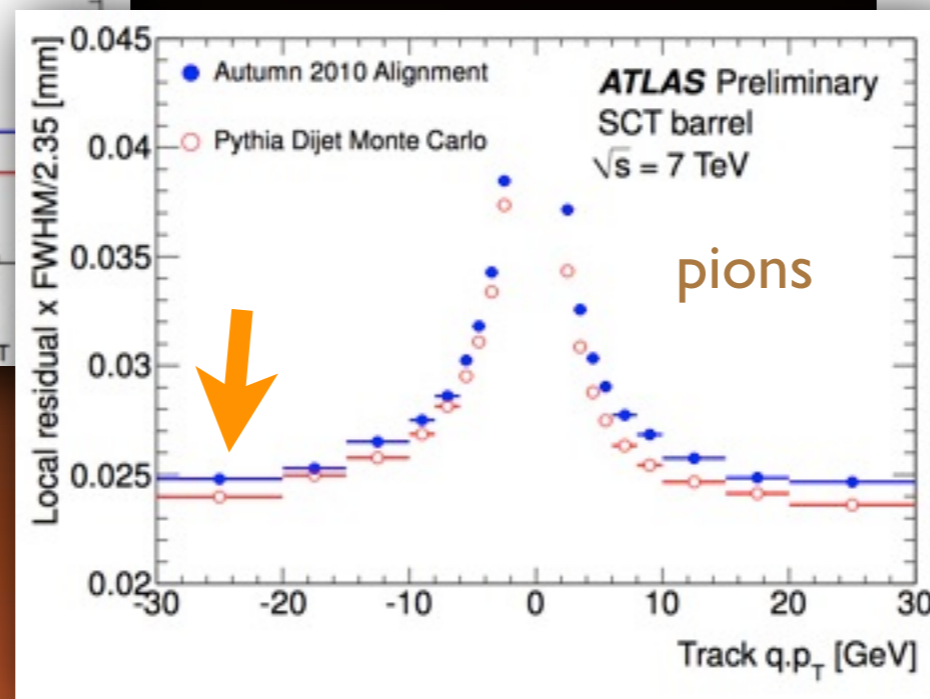
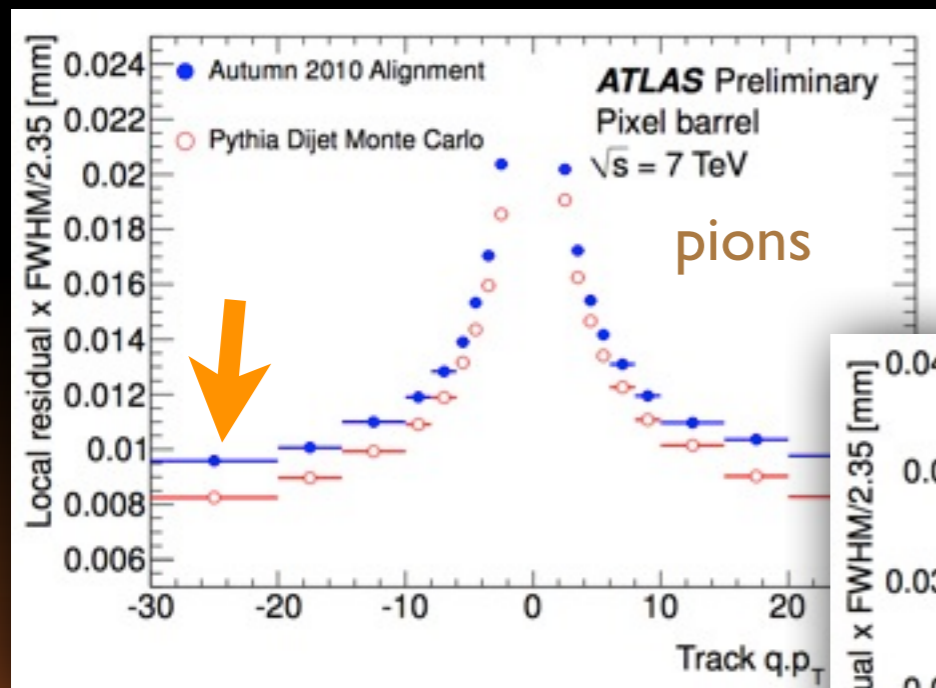
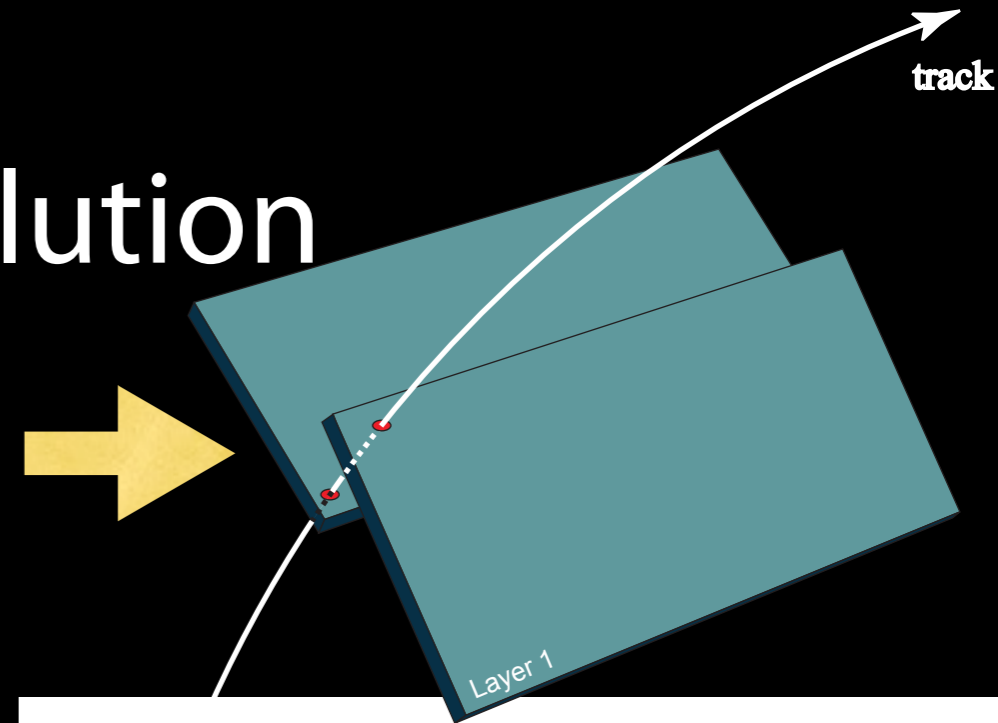

Evidence for Weak Modes ?

example:
curl weak mode

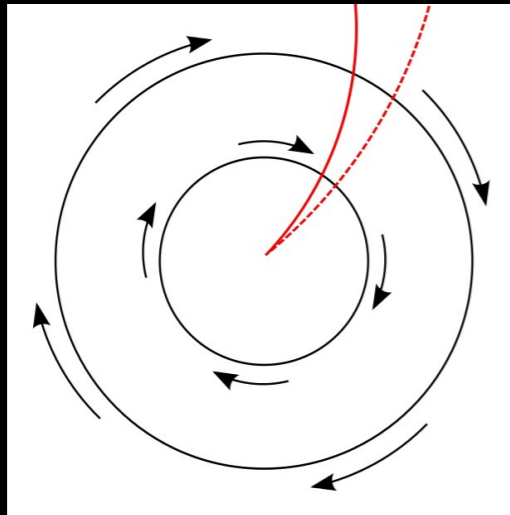

- “weak modes” are global deformations
 - ➔ leave fit- χ^2 nearly unchanged
 - ➔ affect momentum scale, e.g. Z-mass resolution
- limiting performance in data
 - ➔ saw modulation in Z mass vs $\phi(\mu^+)$ in endcaps
- external constraints to control weak modes
 - ➔ TRT to constrain Silicon alignment
 - ➔ currently: electron E/p using calorimeter
 - ➔ check: muon momentum in tracker vs muon spectrometer

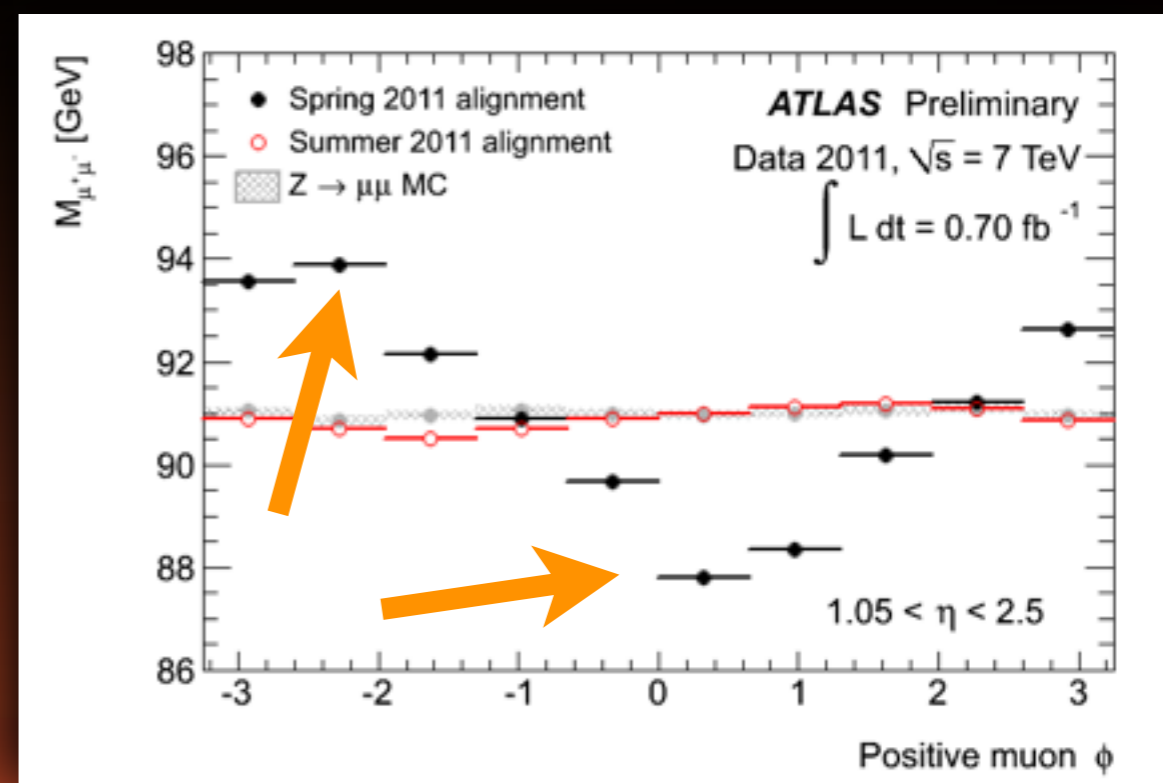
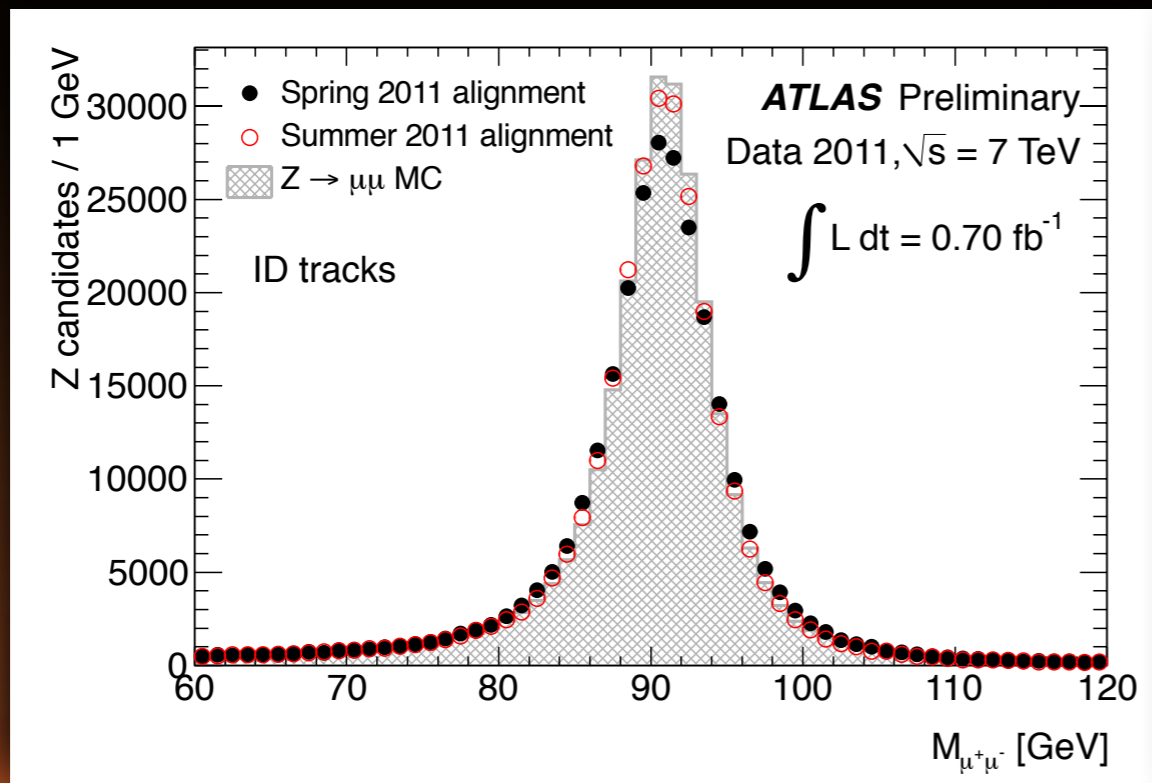

Tracking in Jets

- double track resolution effects ?
 - ➔ study tracks vs p_T of anti- k_T (0.6) jets
- several effects visible in jet core
 - ➔ shared hits in Pixels
 - ➔ TRT association efficiency (quality cuts)
- limits tracking performance
 - ➔ especially for b-tagging !
 - ➔ loss in rejection at high- p_T

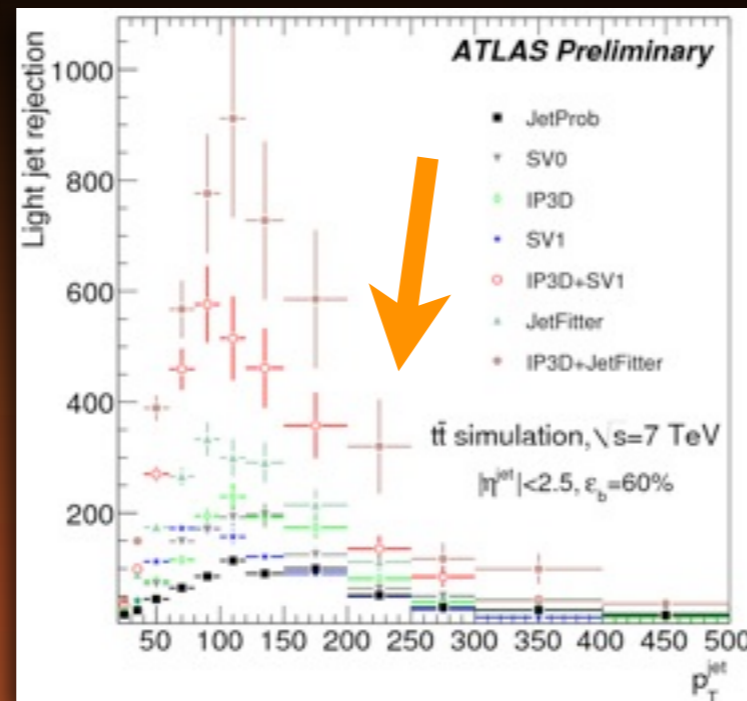
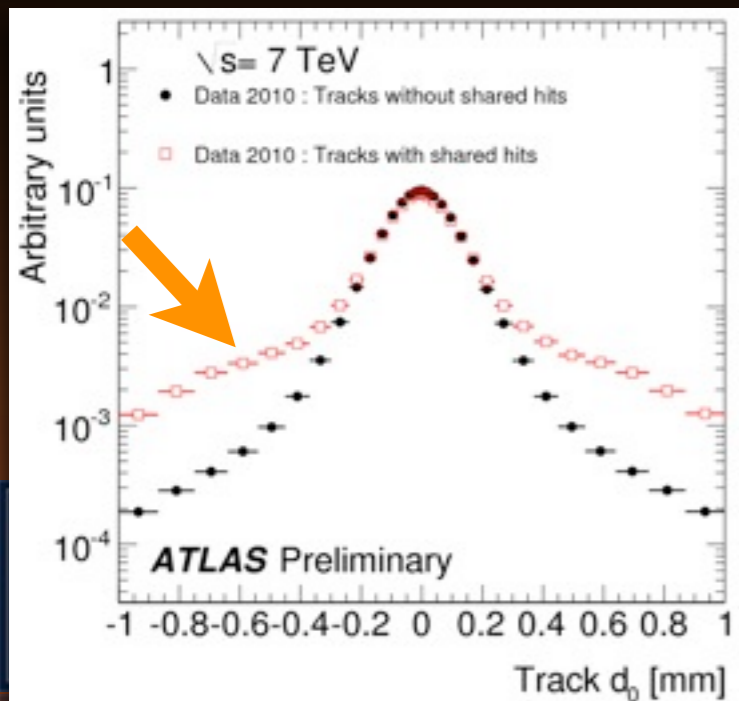
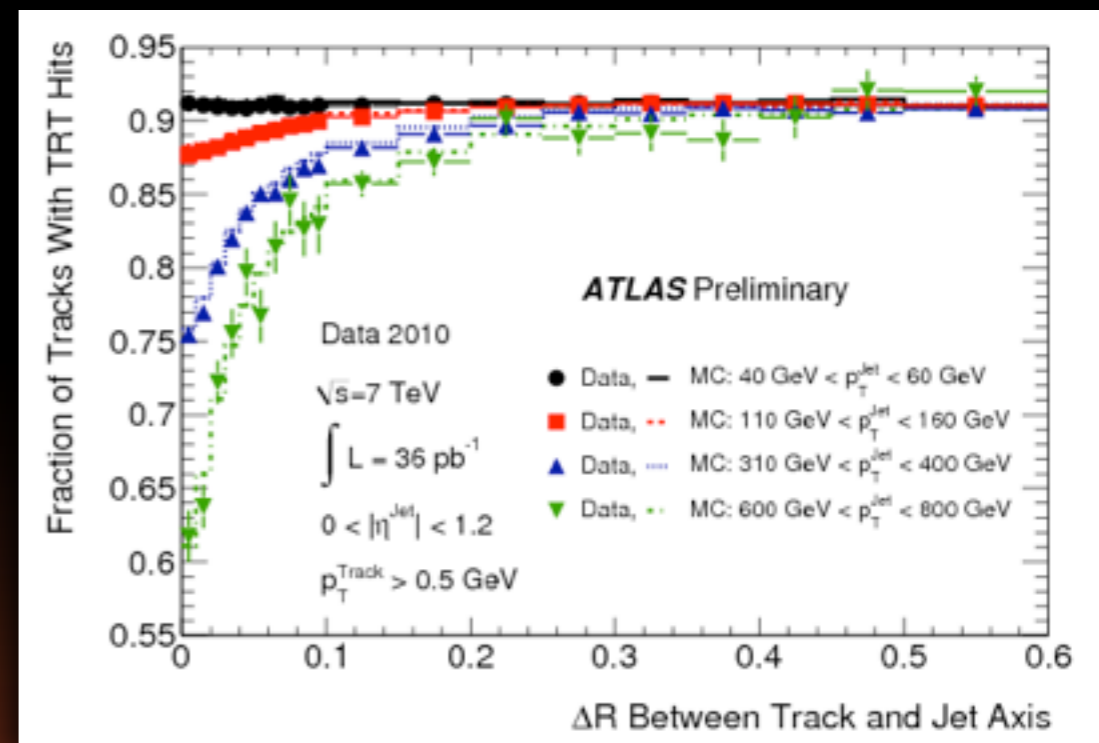
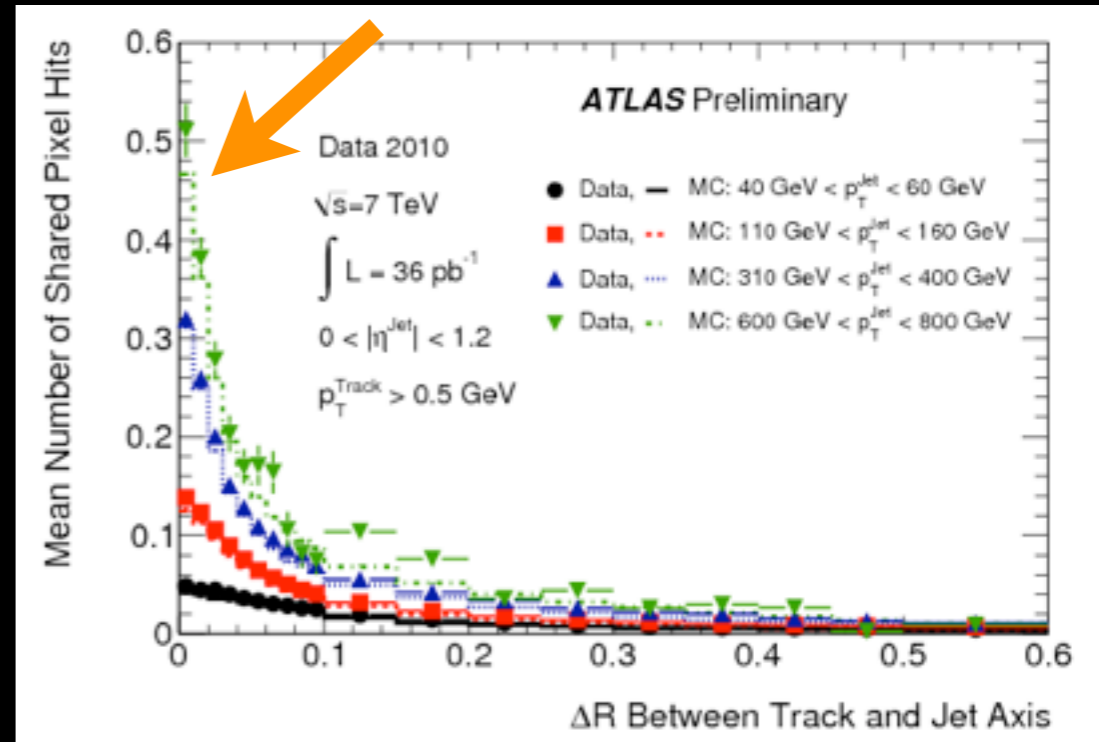

- new clustering to improve
 - ➔ explore full analog information in Pixels

Merged Pixel Clusters

- typical merged cluster with naive clustering algorithm
 - ➔ old clustering was searching for all neighboring pixels that fired
 - ➔ analog information just used to estimate barycenter of cluster

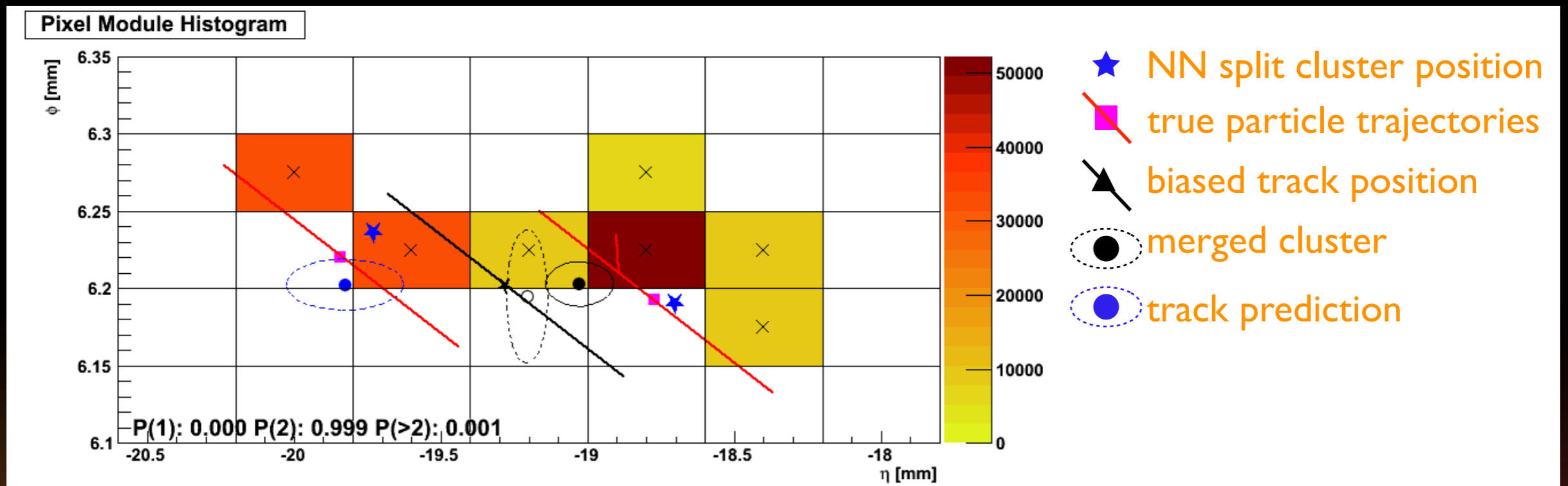

- many merged clusters can be resolved using full analog information
 - ➔ process pre-clusters Pixel information to split them if possible

New Pixel Clustering

- novel algorithm to split merge clusters
 - ➔ neural network (NN) based technique
 - ➔ run 5 networks:
 - NN1: probability a cluster is 1/2/>2 tracks
 - NN2: best position for each (sub)cluster
 - NN3: error estimate for cluster
 - NN4+5: redo NN2+3 using track prediction
 - ➔ adapt pattern recognition
- new clustering been deployed in recent 2011 reprocessing
 - ➔ improved cluster resolution, especially in z
 - ➔ dramatic reduction in rate of shared b-layer hits due to unresolved merged clusters

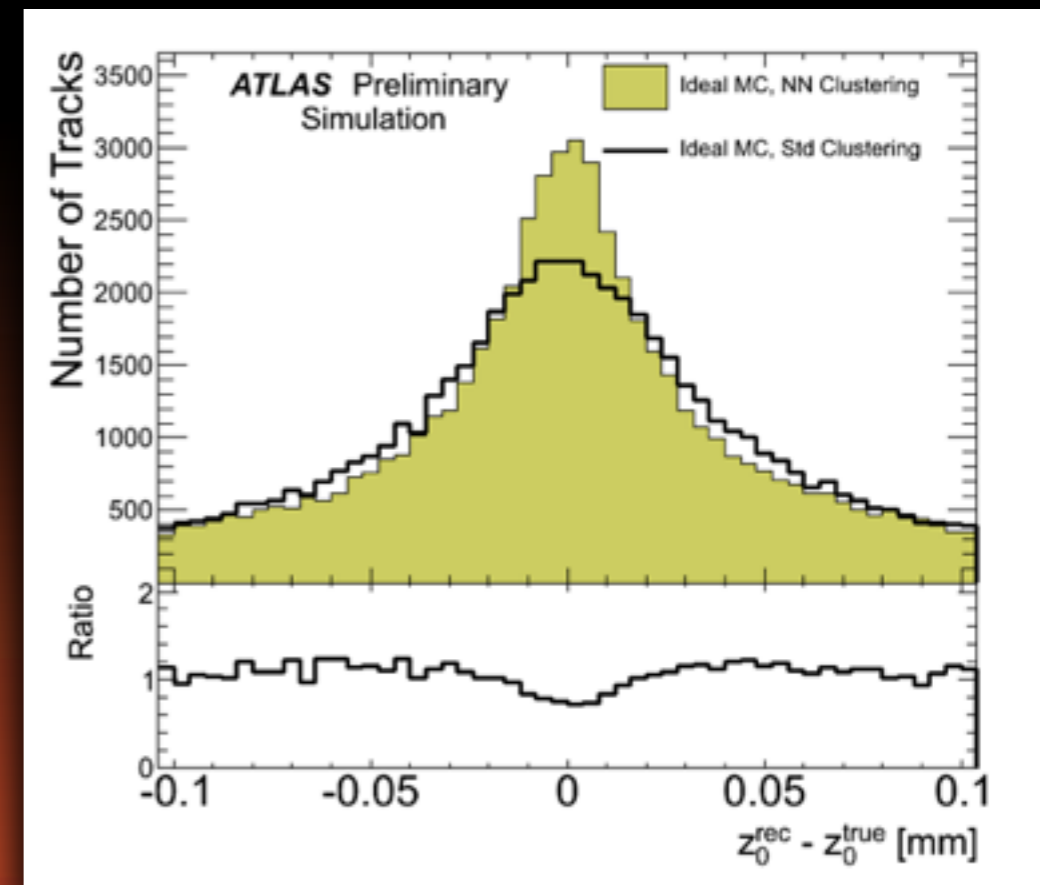
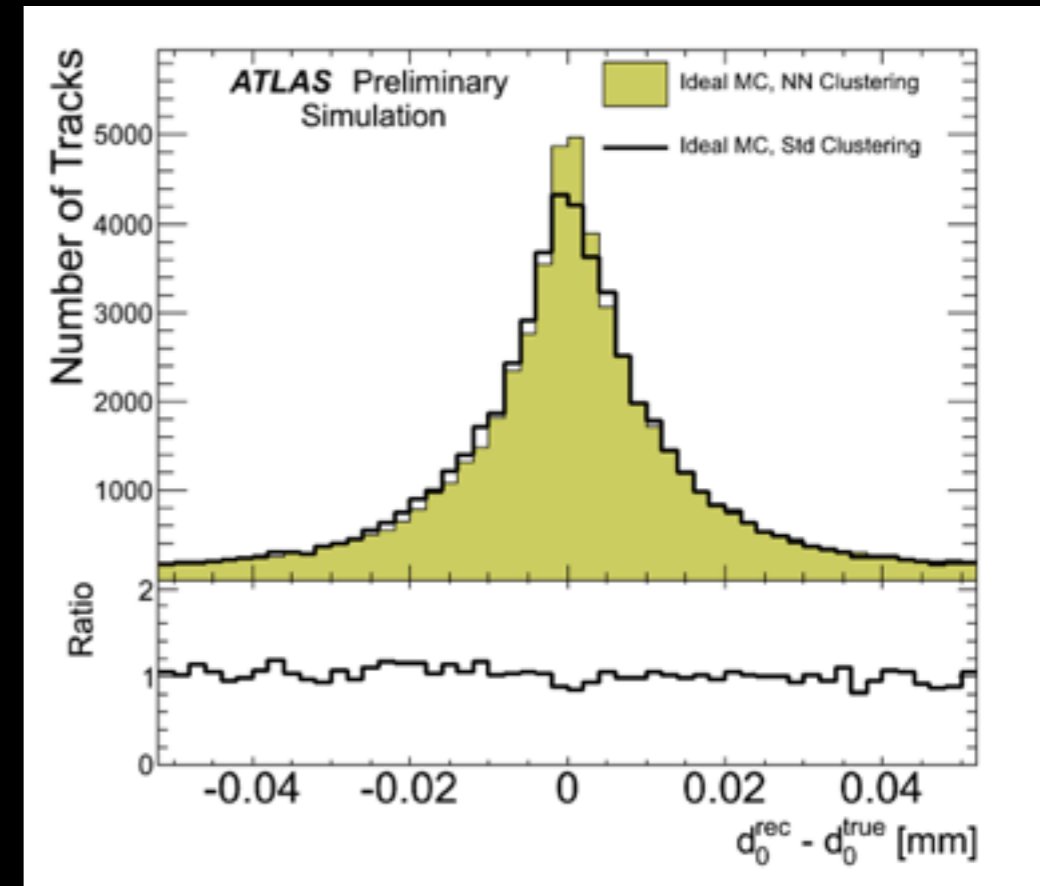

Tracking with Electron Brem. Recovery

- bremsstrahlung in material
 - ➔ significant inefficiency in electron tracking
 - ➔ especially at low p_T (< 15 GeV)
- strategy for brem. recovery
 - ➔ restrict recovery to regions pointing to electromagnetic clusters
 - ➔ pattern: allow for large energy loss in combinatorial kalman filter
 - ➔ global- χ^2 fitter allows for brem. point for final fit
 - ➔ adapt ambiguity processing (etc.) to ensure e.g. b-tagging is not affected
 - ➔ use full fledged Gaussian-Sum Filter in electron identification code
- to be deployed for 2012 data taking

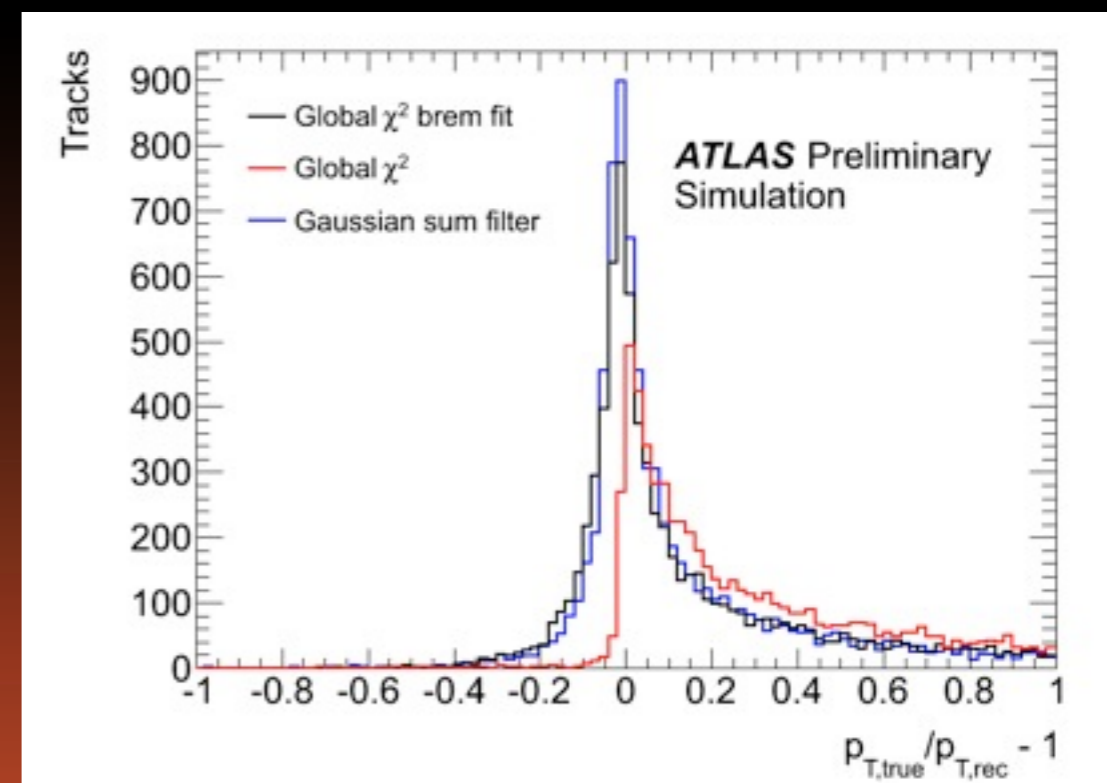
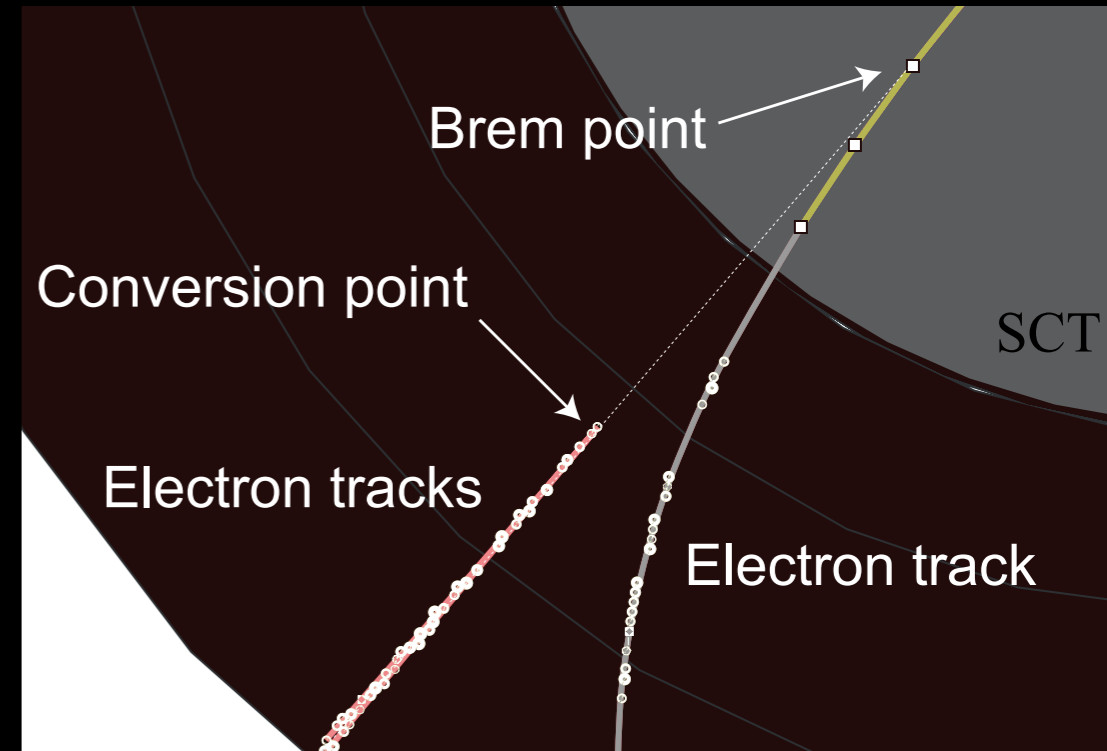

Pileup

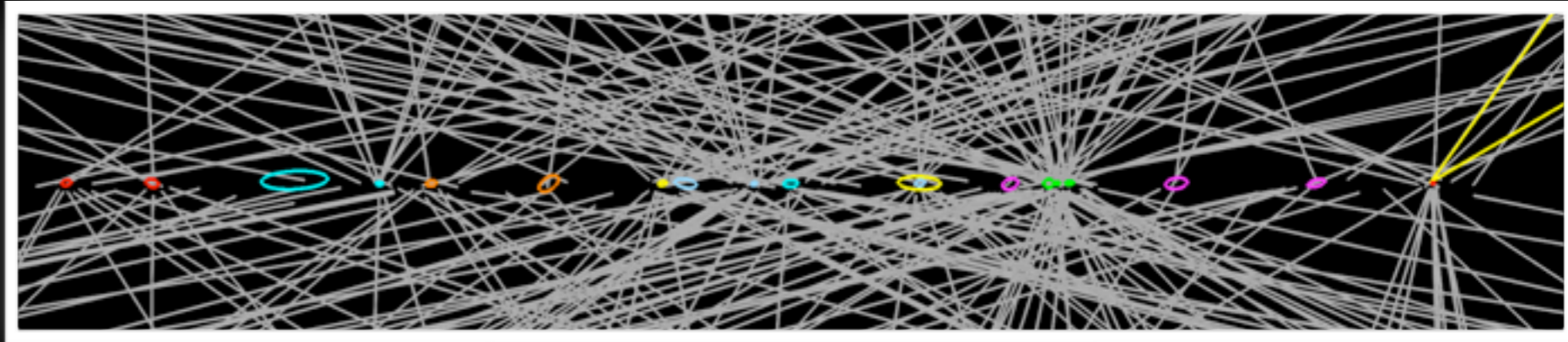

event with 20 reconstructed vertices

- event pileup is a reality
 - ➔ in 2011 we reached **50%** of design levels, but at **50 nsec** bunch spacing
 - ➔ may expect 2-3 times increase in 2012
- occupancies and tracking performance as expected
 - ➔ recent high pileup LHC runs very useful to study high pileup regime
 - ➔ resolutions and reconstruction efficiencies are not affected
 - ➔ fake rate is naturally increasing with loose tracking cuts

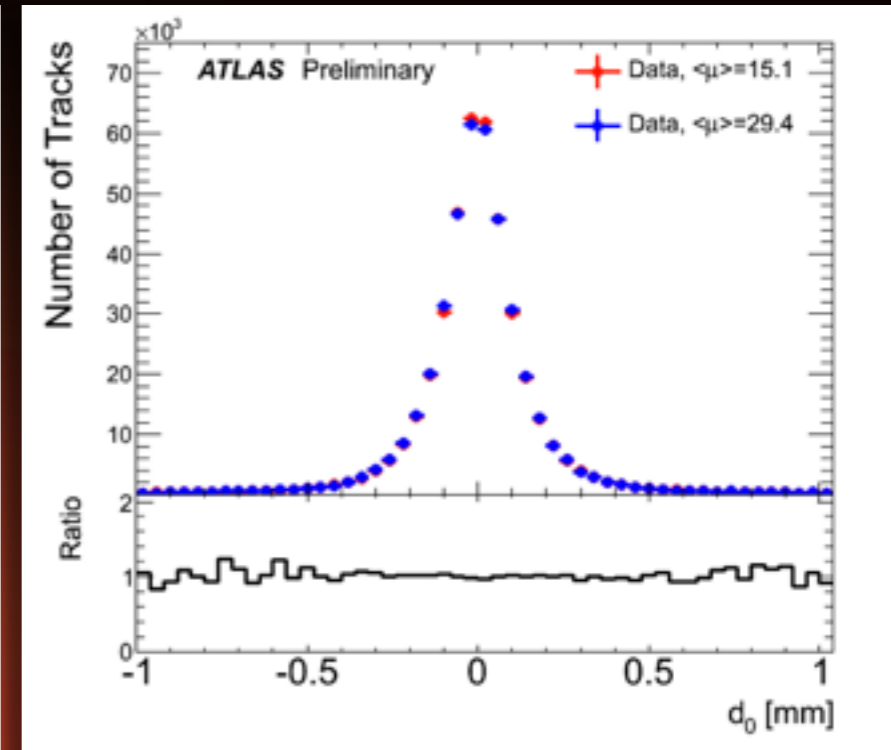
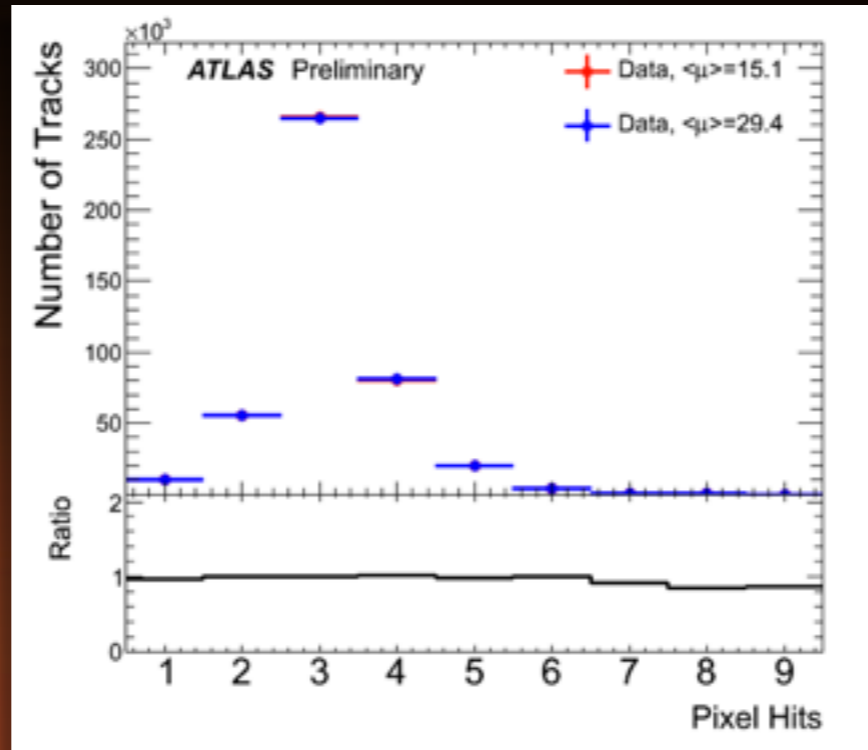
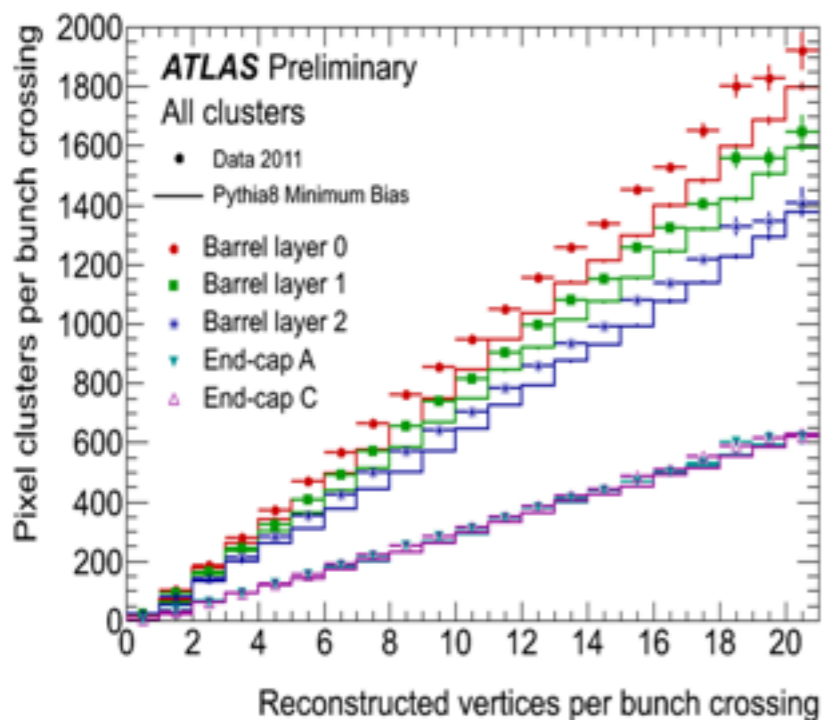

Pileup and Resources

- resource needs scale fast
 - ➔ tracking is a resource driver
- global optimization
 - ➔ requirements on tracking evolves with physics program
 - ➔ different luminosity regimes lead to different **working points**

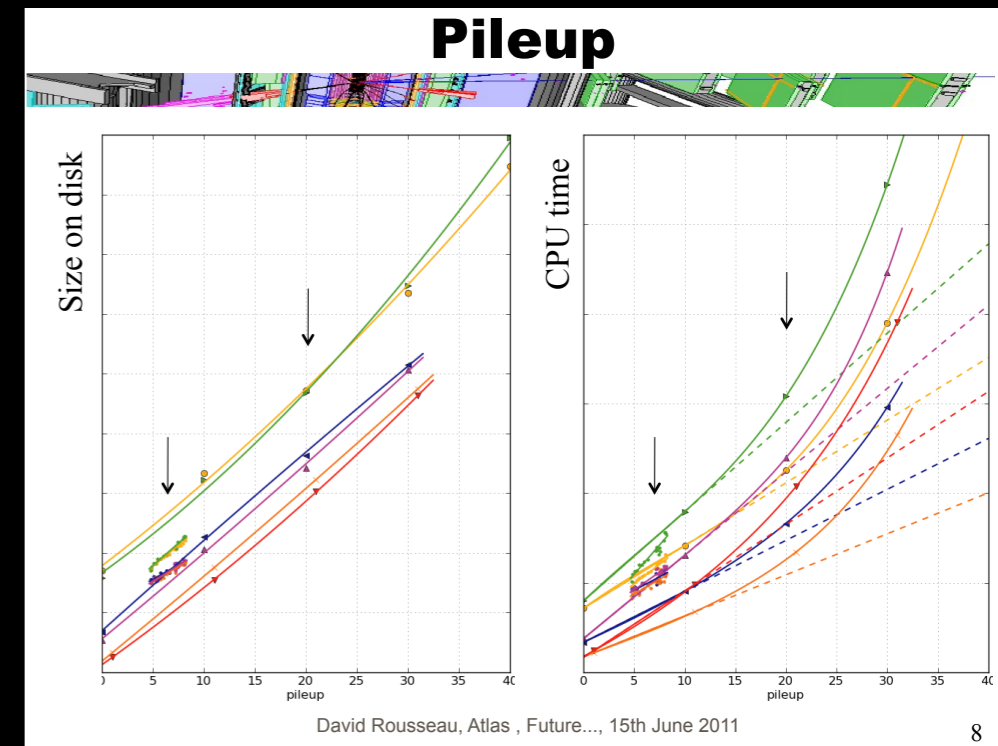

2009 / early 2010	commissioning Min.Bias	pt > 50 MeV open cuts, robust settings min. 5 clusters
2010 stable running < ~4 events pileup	low lumi physics program (soft QCD, b-physics, ...), b-tagging...	pt > 100 MeV min. 7 clusters
2011 pp running ~11 events pileup	focus more on high-pt physics (top, W/Z, Higgs), b-tagging...	pt > 400 MeV, harder cuts in seeding min. 7 clusters
Phase I upgrade including IBL 24-50 events pileup	high-pt physics, study new physics (I hope), b-tagging....	pt > 900 MeV, harder tracking cuts, min. 9 clusters
SLHC up to 100-200 events pileup	replace Inner Detector to cover very high luminosity physics program	further evolve strategy... R-o-l or z-vertex seeding, reco. per trigger type, GPUs



Heavy Ion Tracking

- high multiplicity tracking
 - ➔ adapt seed finding
(z vertex constraint to save CPU)
 - ➔ tighten hit requirement to control fakes in central events (similar to sLHC setup)
- excellent tracking performance
 - ➔ even in central events
 - ➔ performance well described by MC
 - ➔ good testing ground for high in-time pileup with data

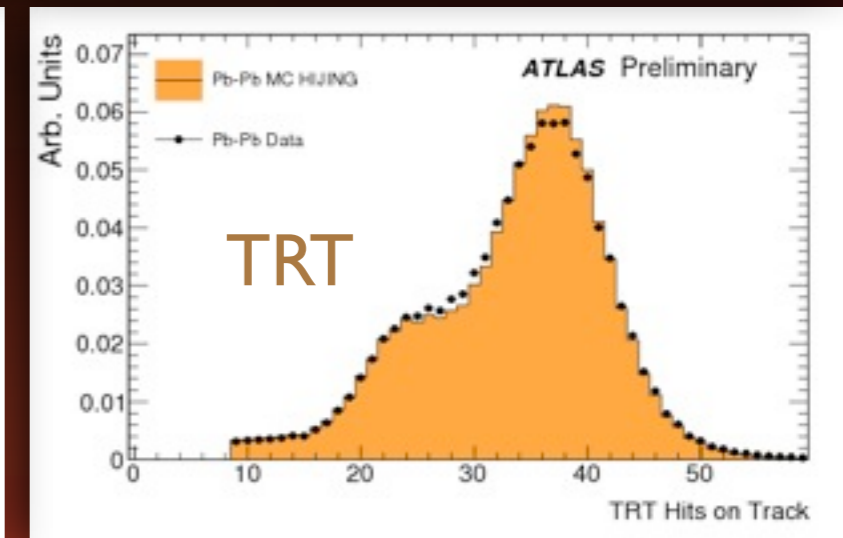
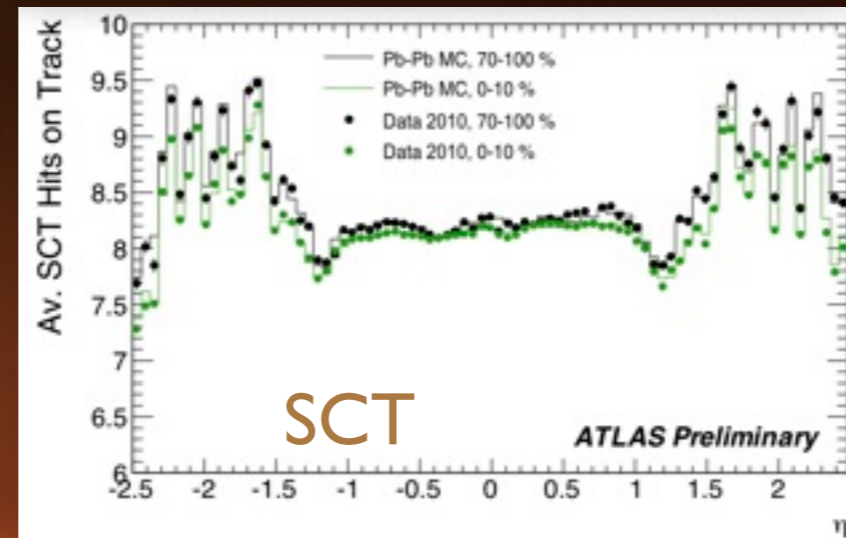
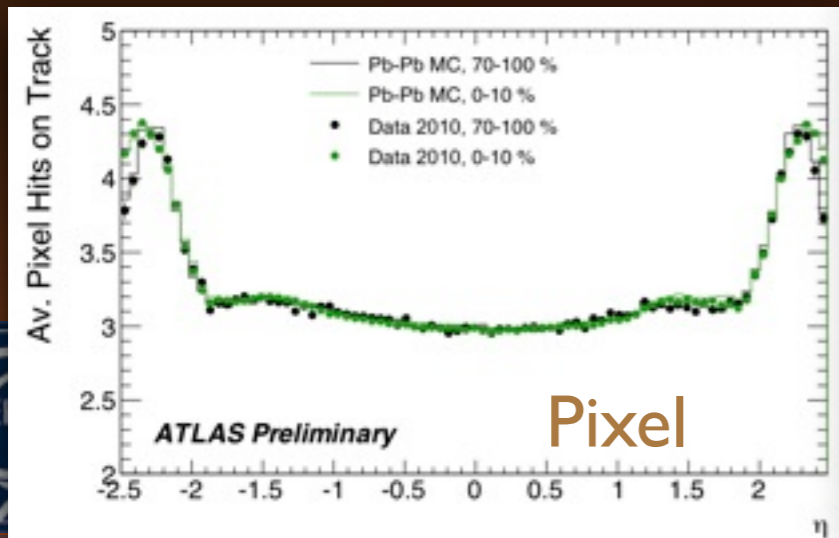
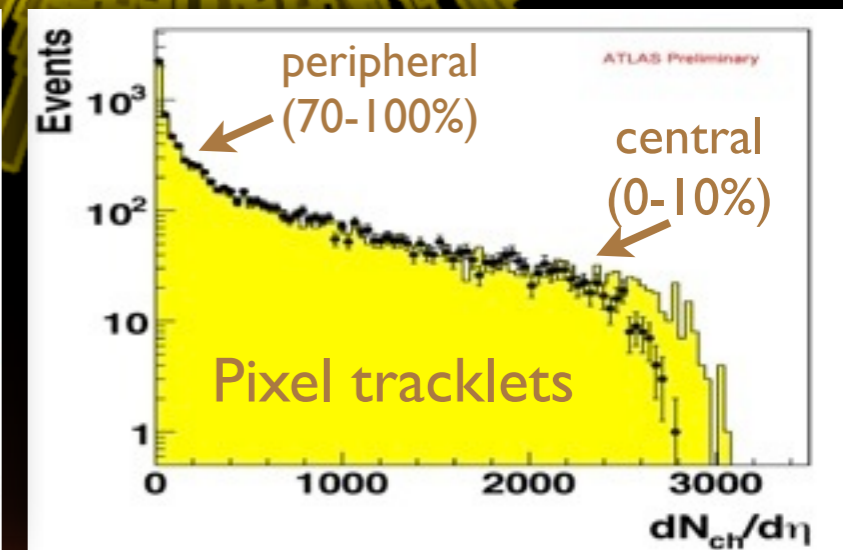
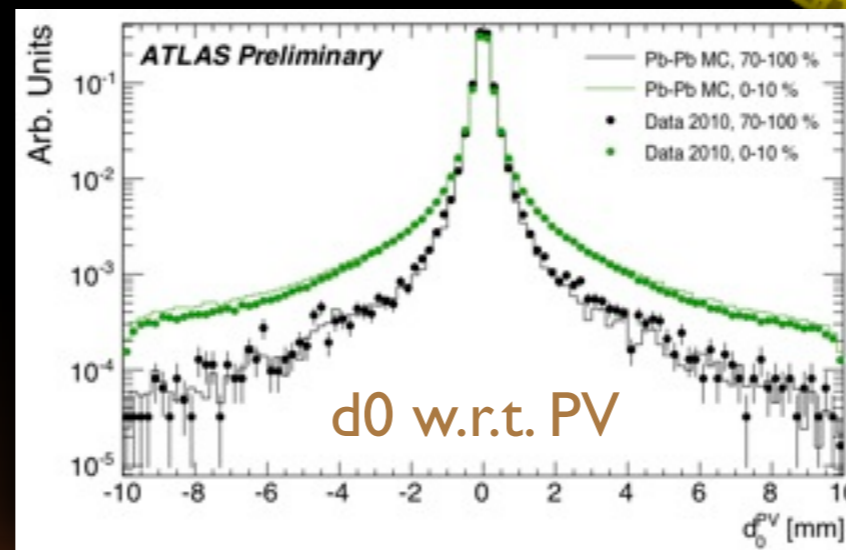
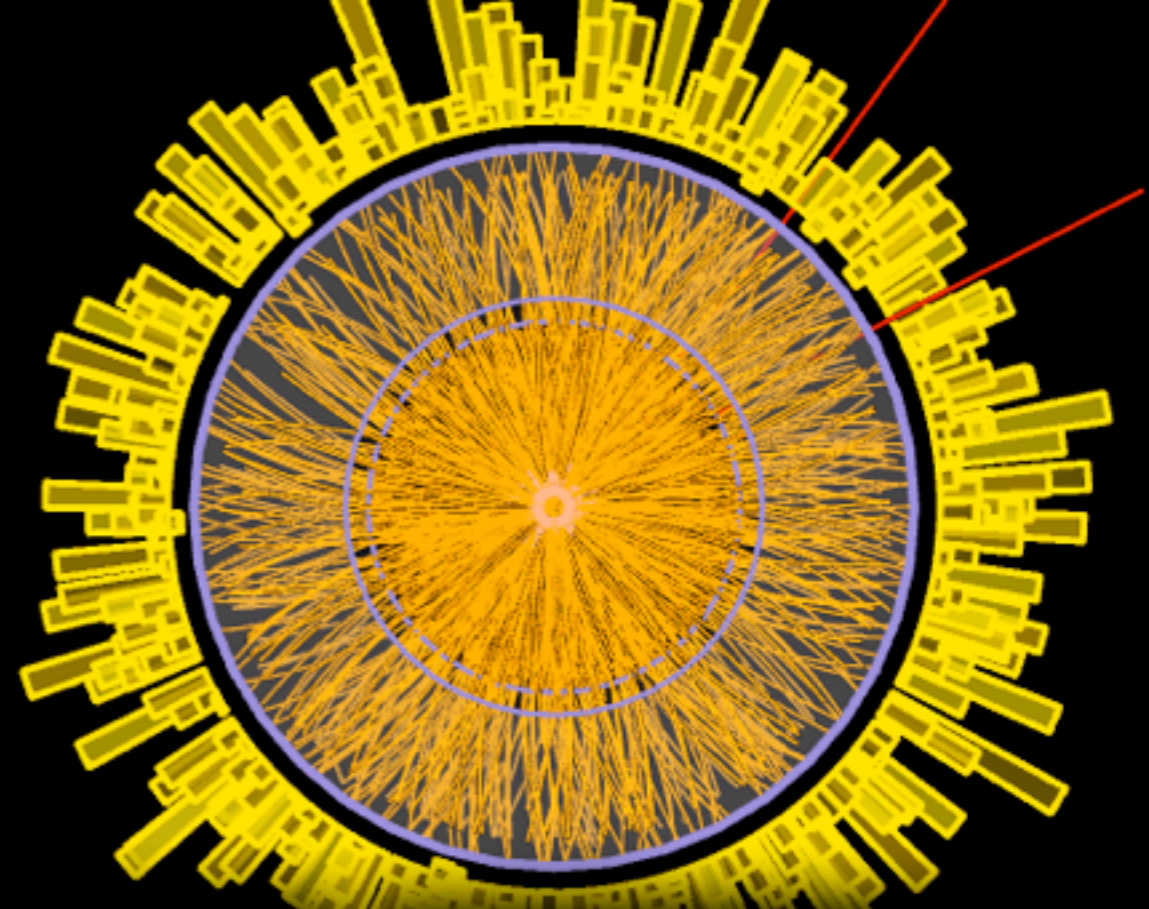

Radiation Damage

- effects became visible in last year with increasing luminosity
 - ➔ b-layer designed for
 - $\phi = 2.43 \cdot 10^{12} \cdot (1 \text{ MeV neq})/\text{fb}^{-1}$
 - type inversion at $\sim 10 \text{ fb}^{-1}$
- monitor radiation effects on silicon
 - ➔ leakage current and cross talk measurements
- currents from HV power supplies
 - ➔ compare measured leakage currents with:
 - lumi profile
 - expected fluence ϕ from PhoJet/Fluka
 - silicon volume
 - damage constant α from test beam
 - ➔ good agreement for Pixels and SCT after correction for annealing periods
 - cooling off, e.g. during technical stops

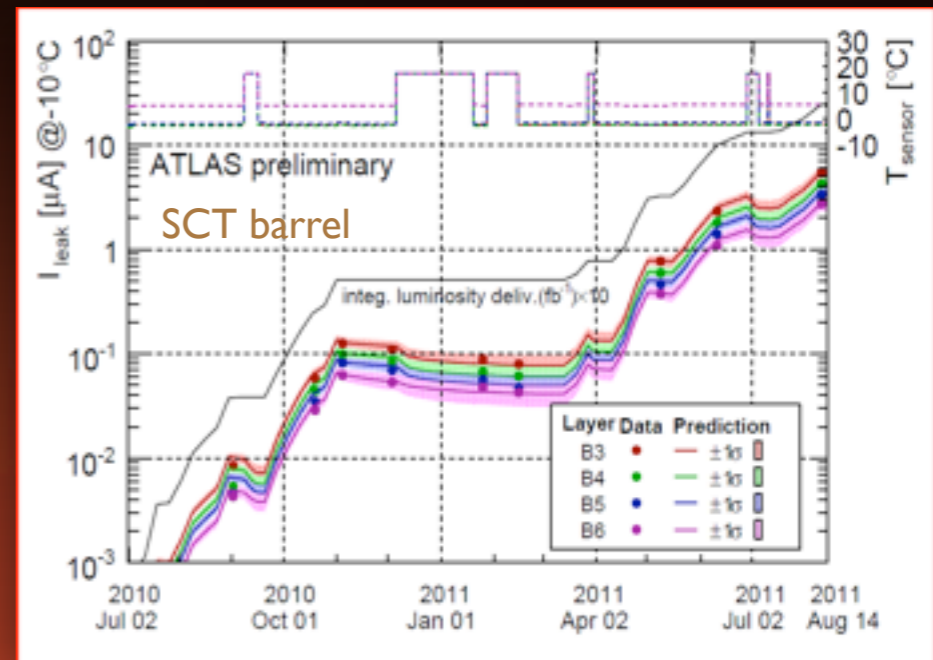
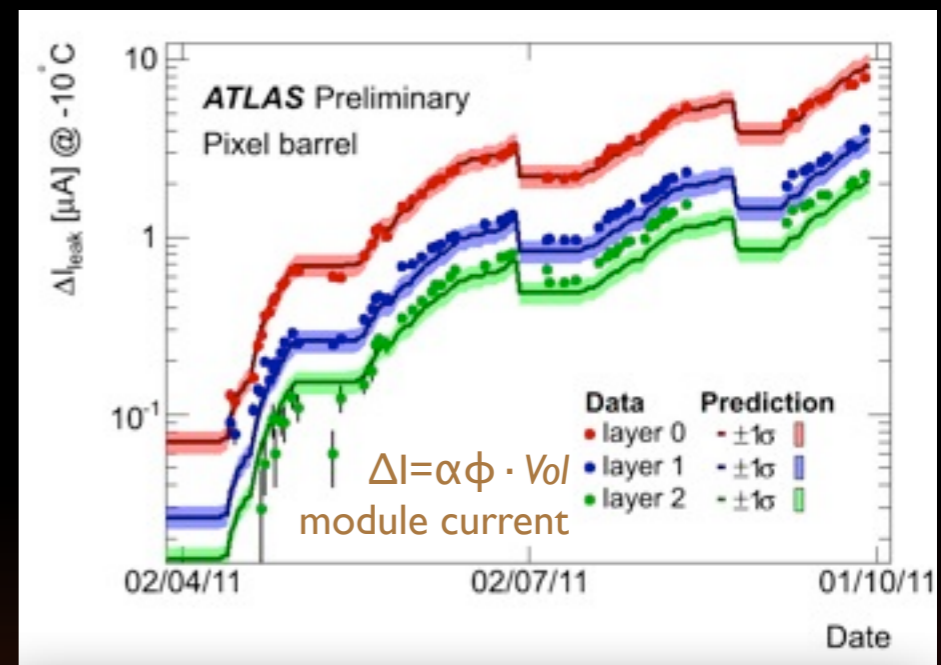
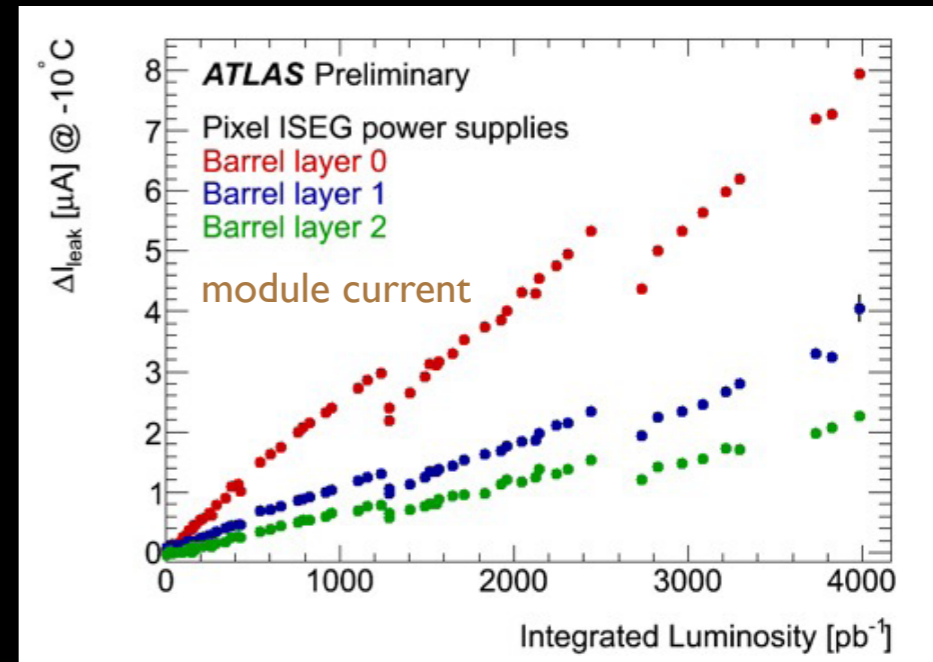

Primary Vertex Reconstruction

- beam spot routinely determined
 - ➔ averaged over short periods of time (LB)
 - ➔ input to primary vertex reconstruction as a constraint
- primary vertex finding
 - ➔ ATLAS (and CMS) use an iterative vertex finder and an adaptive fitter
 - ➔ some reduced efficiency for min.bias pileup vertices vs $\langle \mu \rangle$

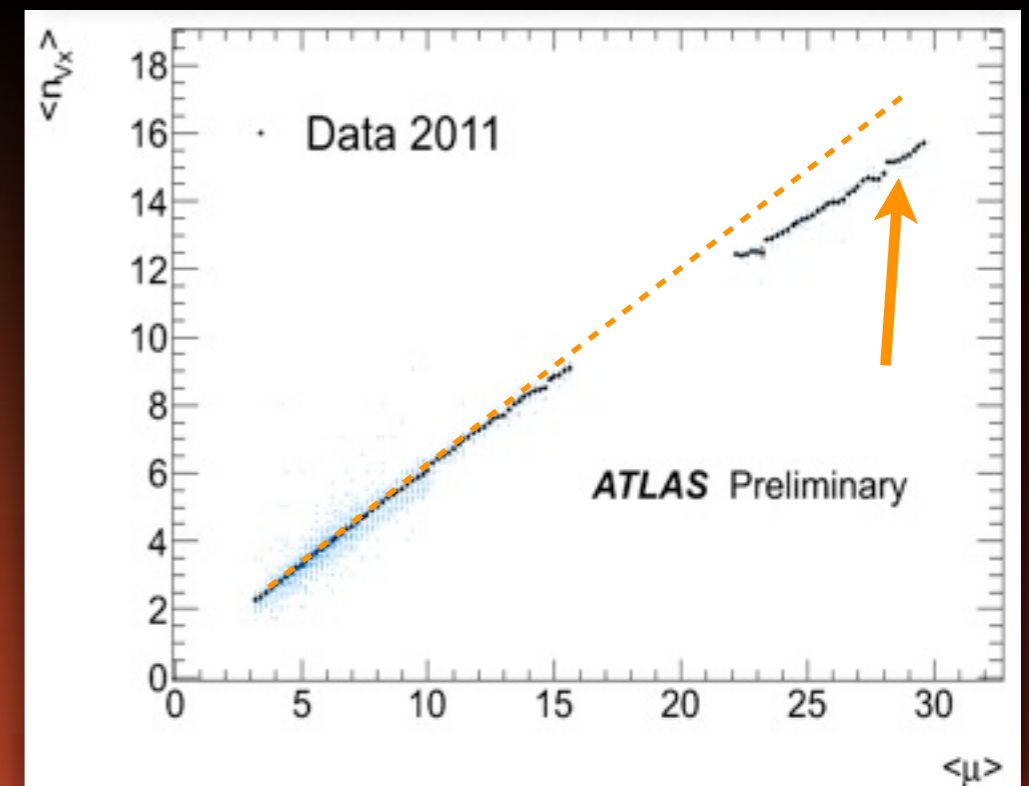
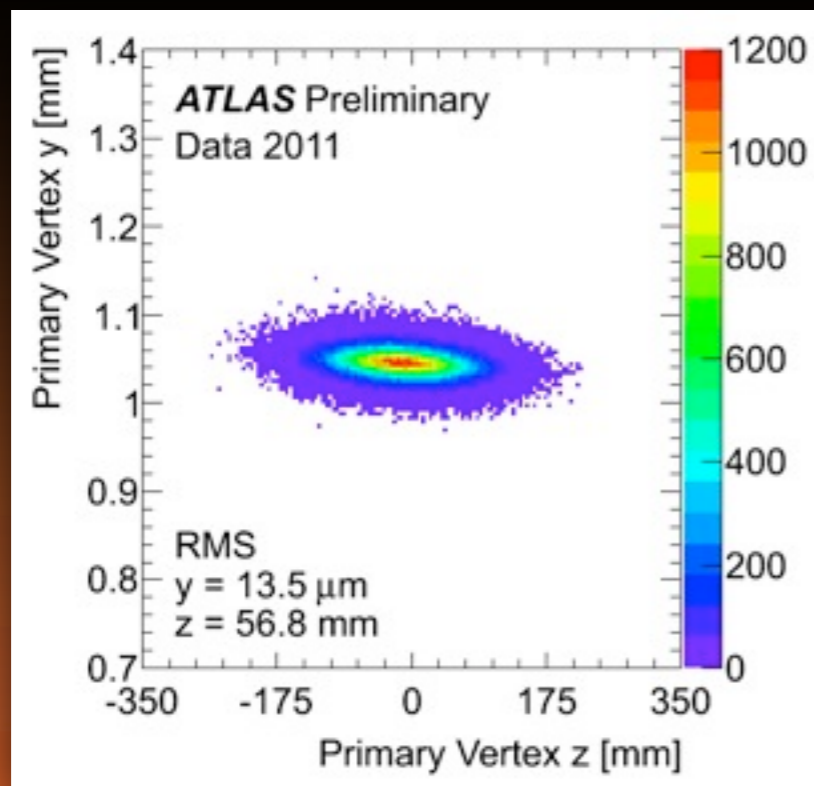
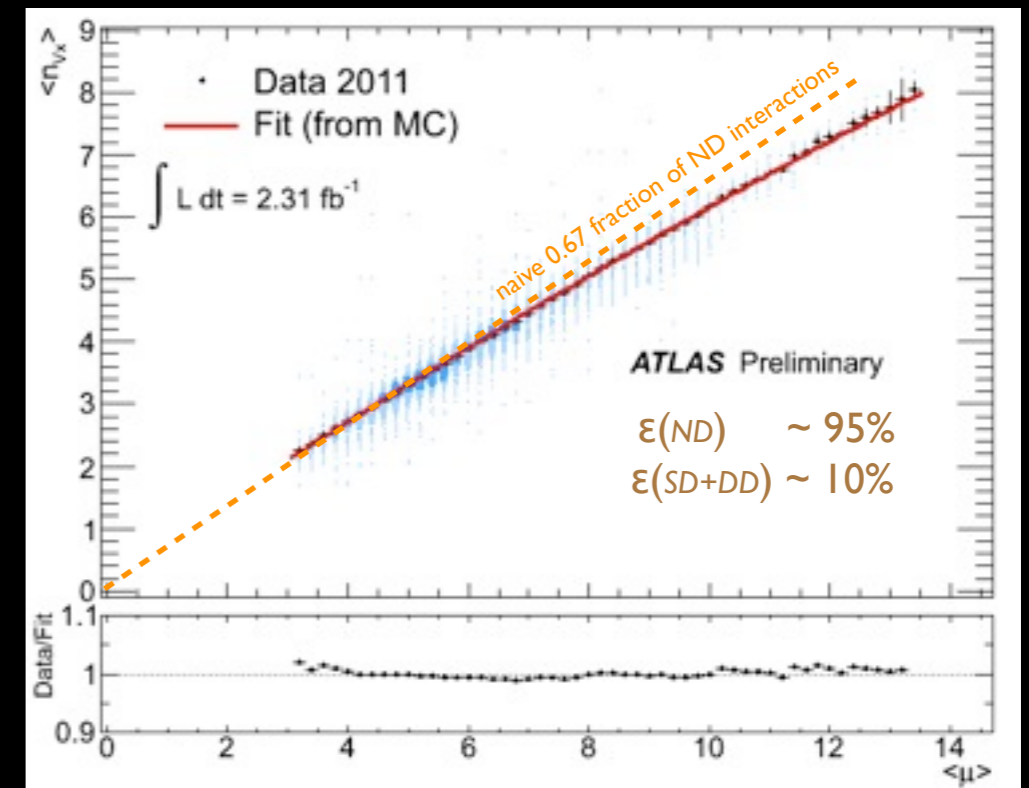

b-Jet Tagging

- “early tagging” techniques
 - ➔ **soft lepton** tagger
 - ➔ **track counting** of significant IP offsets
 - ➔ **jet probability**
 - construct probability that IP significance of all tracks in jet is compatible with PV
 - ➔ **secondary vertex** (SV) tagger
 - decay length significance

- more elaborate taggers
 - ➔ use multi-variant techniques to classify jets
 - ➔ construct IP based likelihood using b/c/light templates (**IP2D** and **IP3D**)
 - ➔ combined likelihood taggers using IP and secondary vertex information (**IP3D+SV0**)
 - ➔ vertex decay chain tagger (**JetFitter**)
 - ➔ in regular use since last summer

- data driven performance studies !

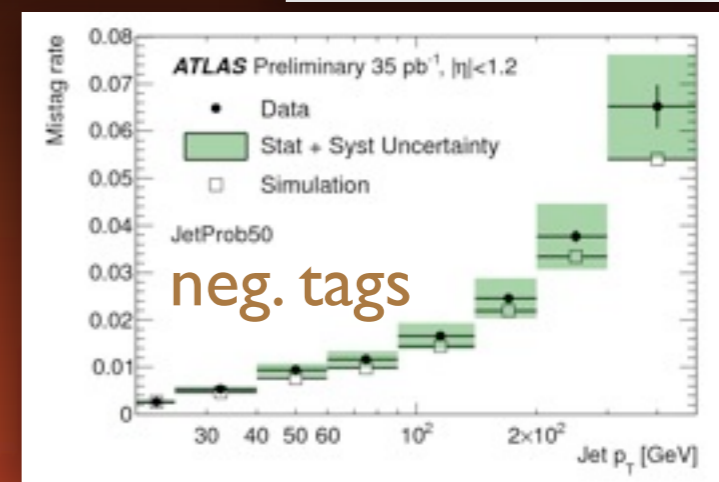
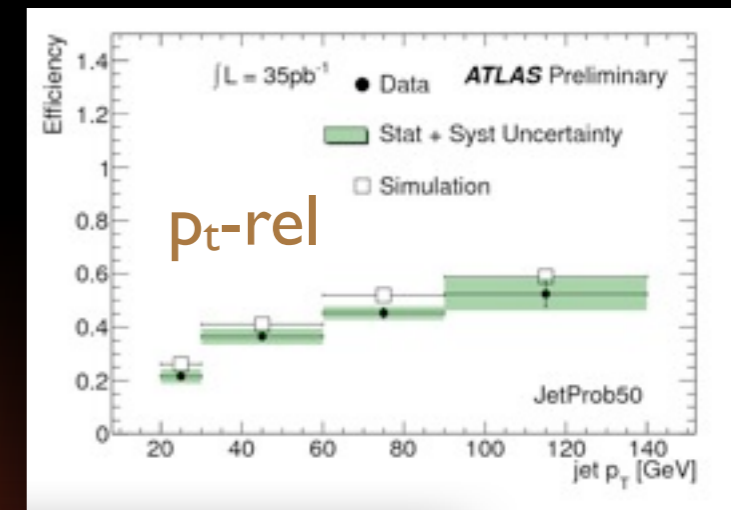
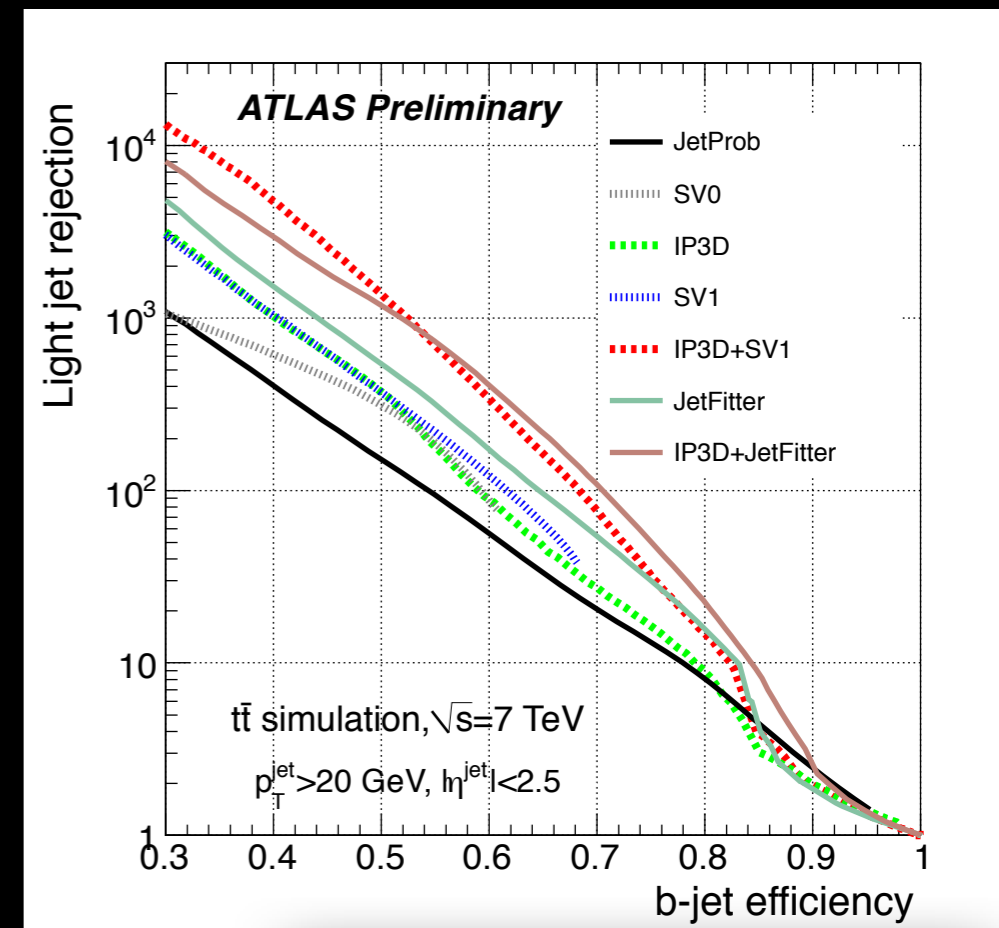

JetFitter as a b-Jet Tagger

- conventional vertex tagger
 - ➔ fits all displaced tracks into a common geometrical vertex

- JetFitter

- ➔ **b-/c**-hadron vertices and primary vertex approximately on the same line
- ➔ fit of **1..N** vertices along jet axis
- ➔ mathematical extension of conventional Kalman filter vertex fitter

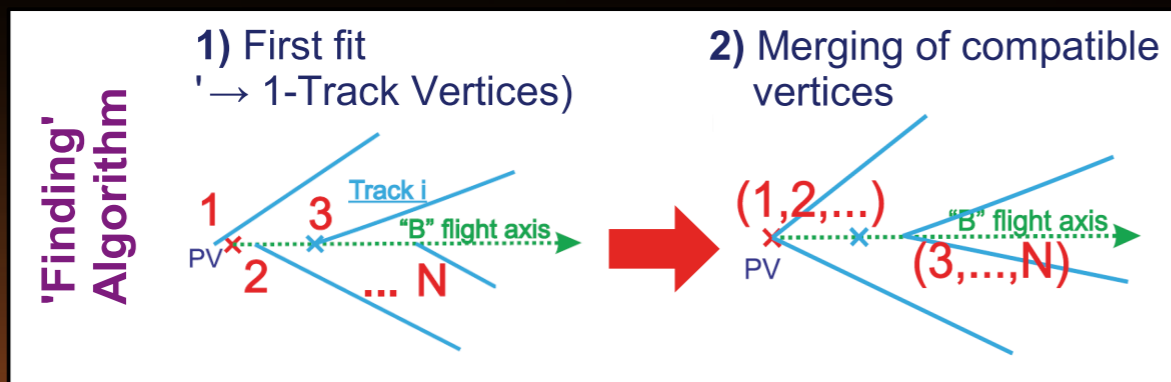

- up to **40%** better light rejection
 - ➔ IP3D+JetFitter is best b-jet tagger in use in ATLAS today

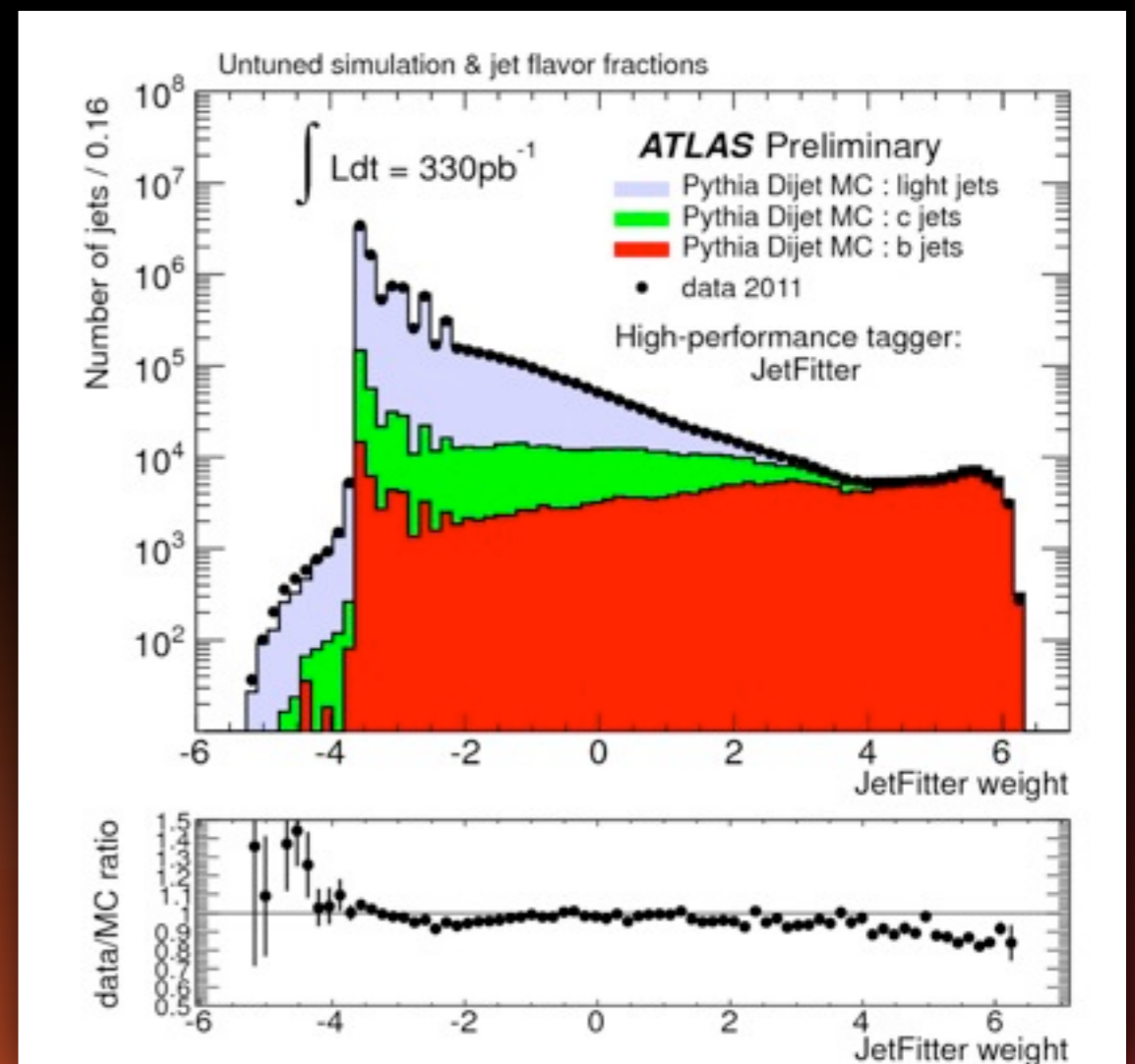
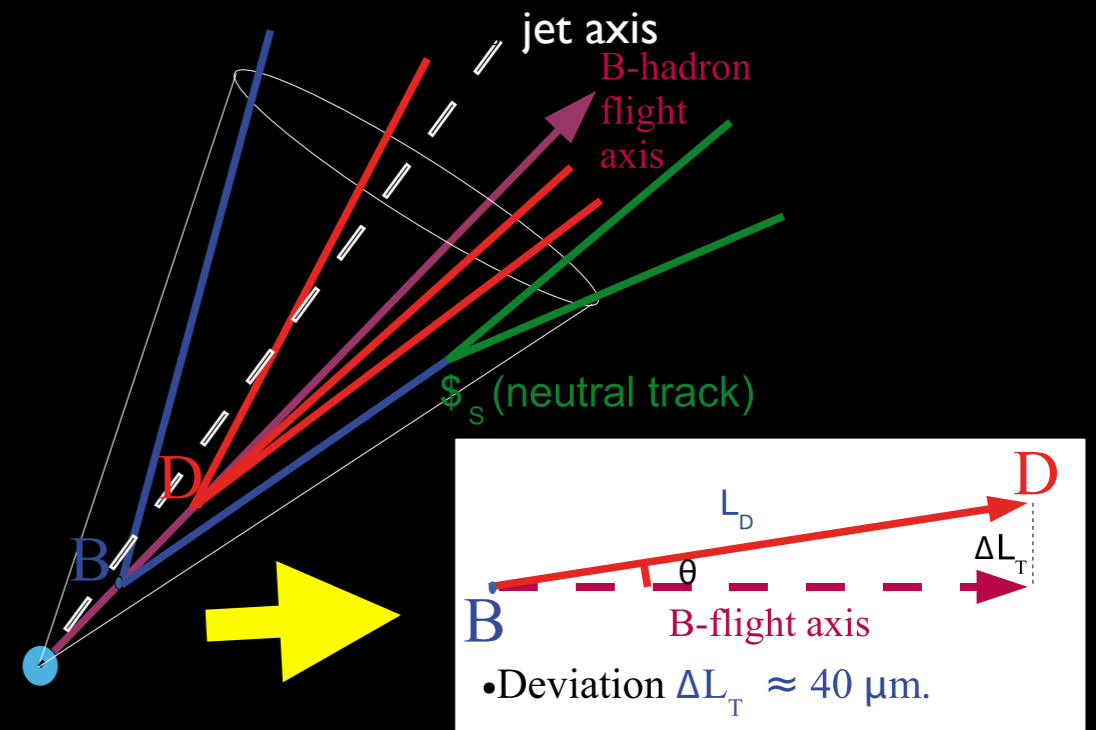

Tracker related upgrades

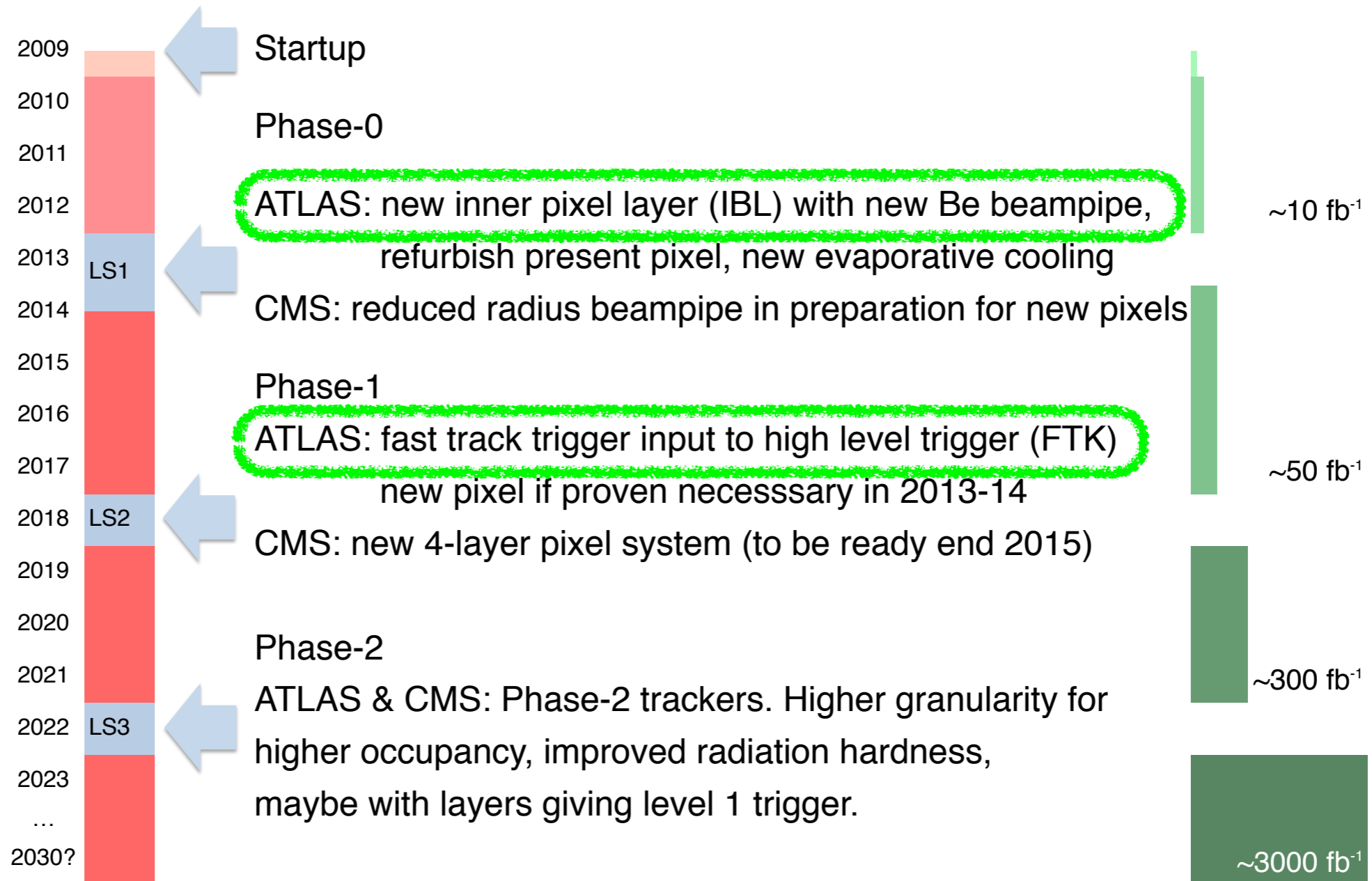

Upgrade: IBL Tracking

- performance studies in G4
 - ➔ smaller beam pipe ($R_{\min} = 25 \text{ mm}$)
 - ➔ reconstruction: 4th Pixel layer
 - ➔ IBL material adjusted to $1.5\% X_0$
 - ➔ smaller z pitch (**250 μm**)
- installation next shutdown
 - ➔ ready for 14 TeV running
 - ➔ peak luminosities of $2 \cdot 10^{34} \text{ cm}^{-2}\text{s}^{-1}$
 - ➔ **25-50** pileup events

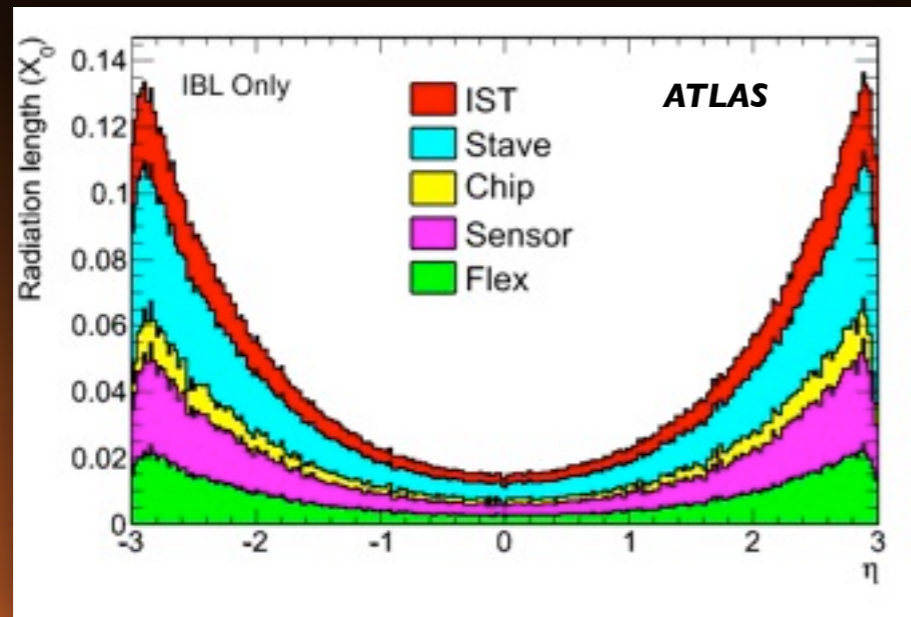
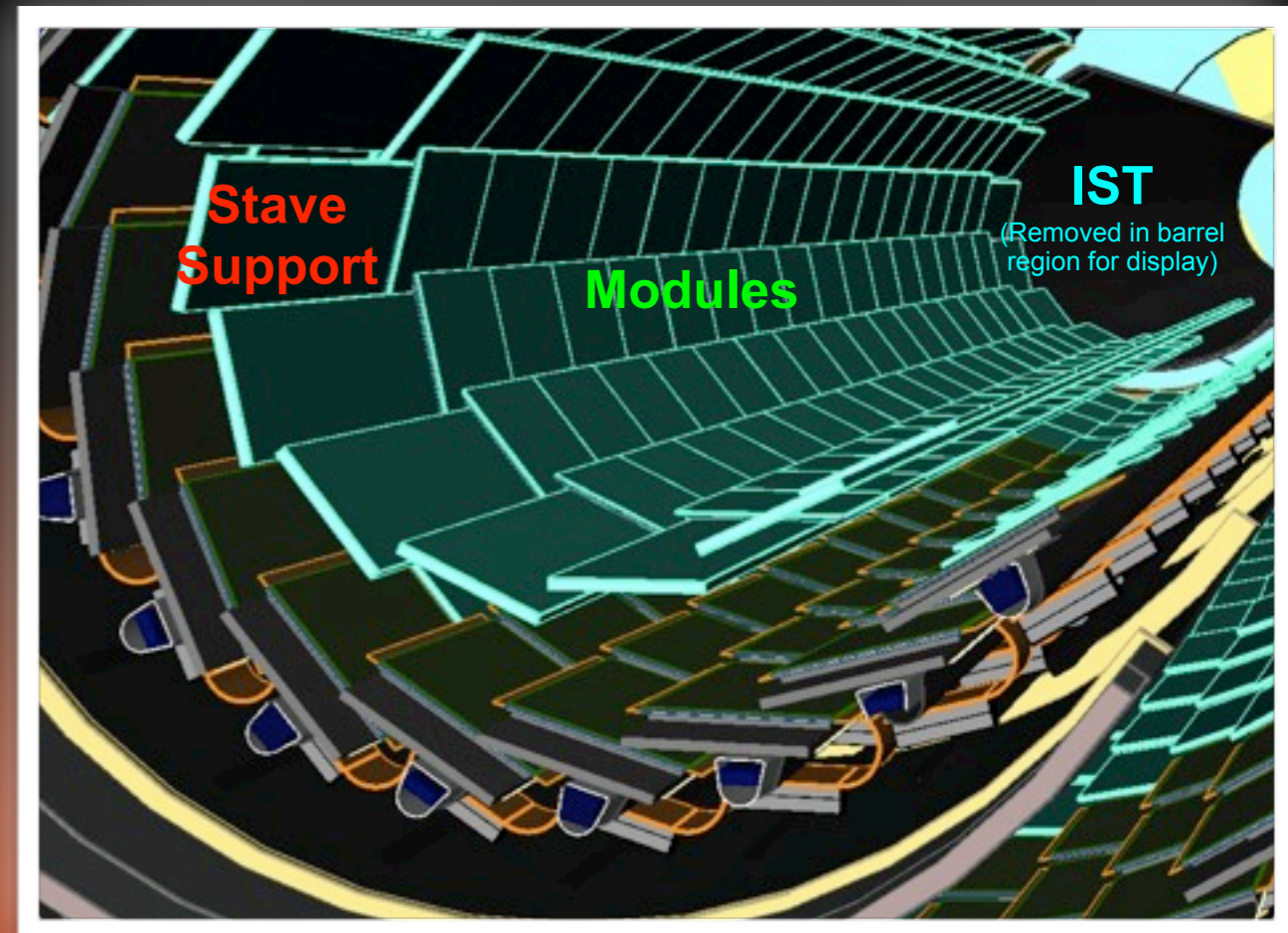
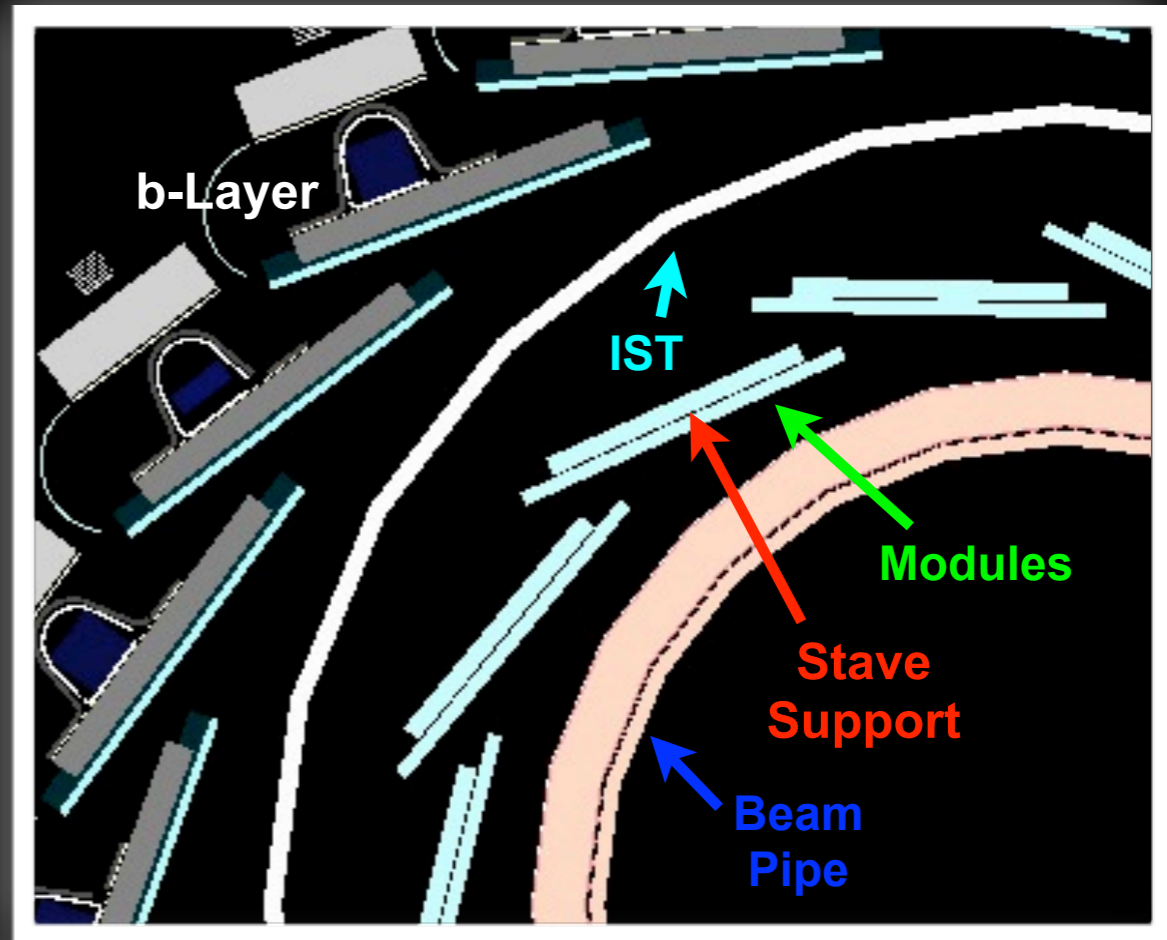

New FE-14 Chip

- 4bit (FE-14) calibration vs 8bit (FE-13)

- ➔ different dynamic range
 - and FE-14 allows for overflows
- ➔ average cluster size in IBL bigger than in b-layer
 - broader spectrum of incident angles

- compare cluster resolutions IBL (FE-14) and b-layer (FE-13)

- ➔ similar in X_{local} , pitch drives improvement in Z_{local}

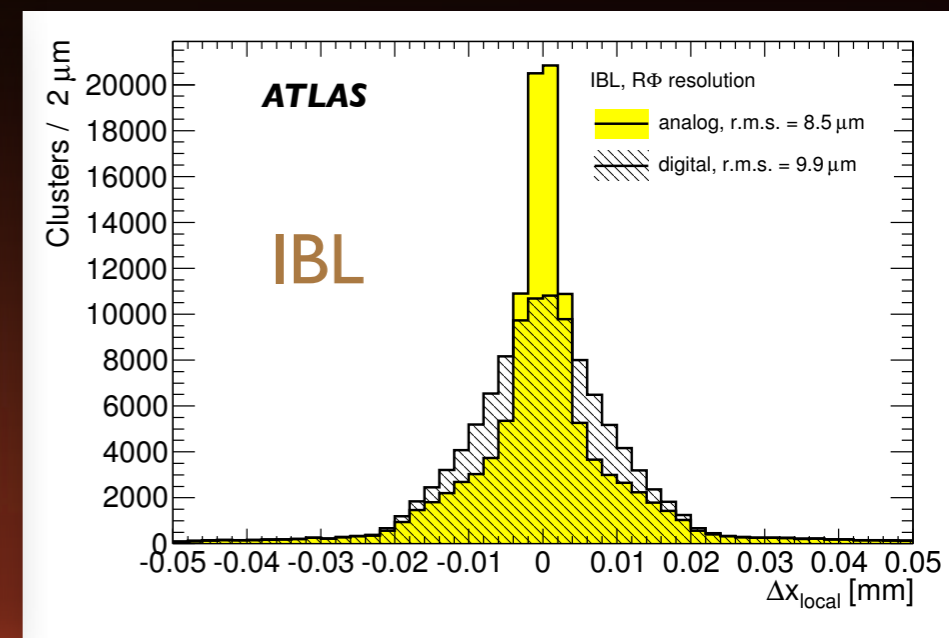
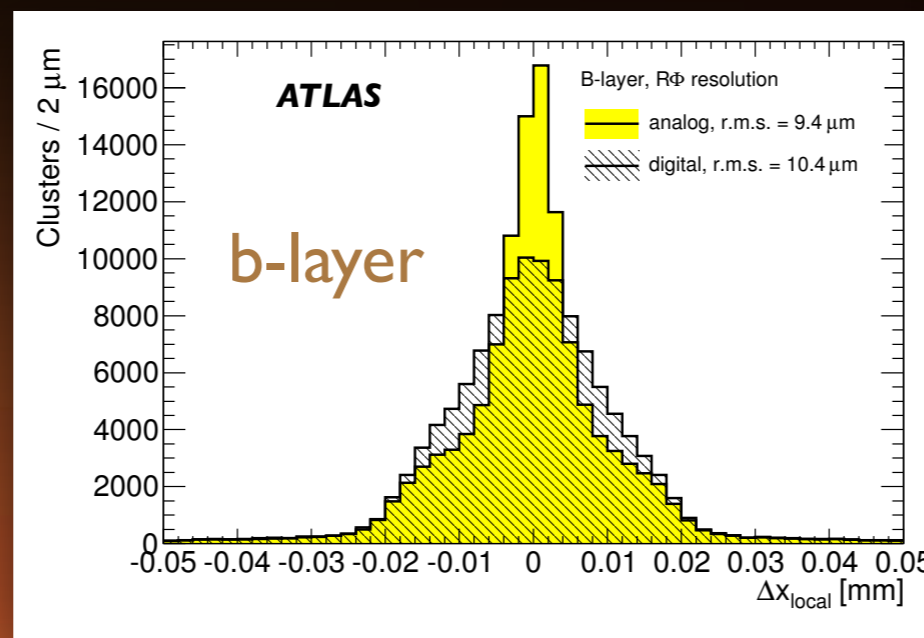
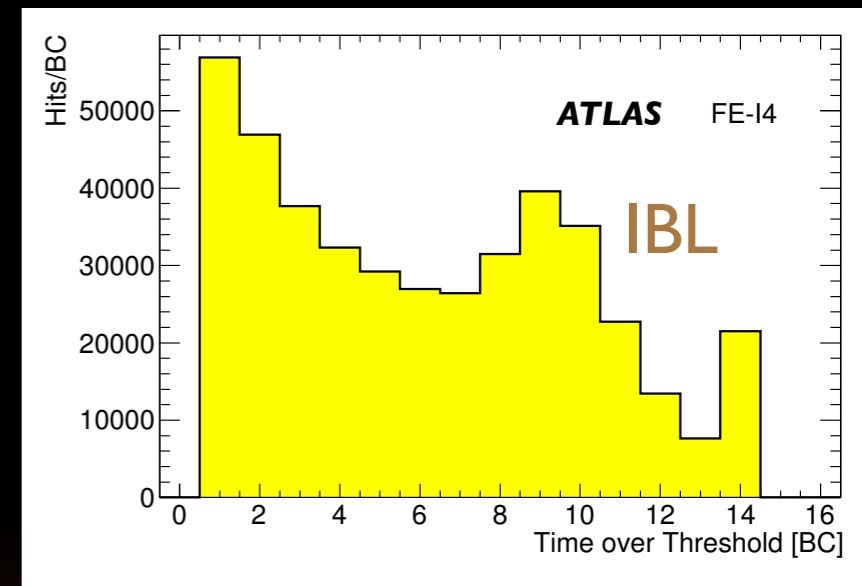
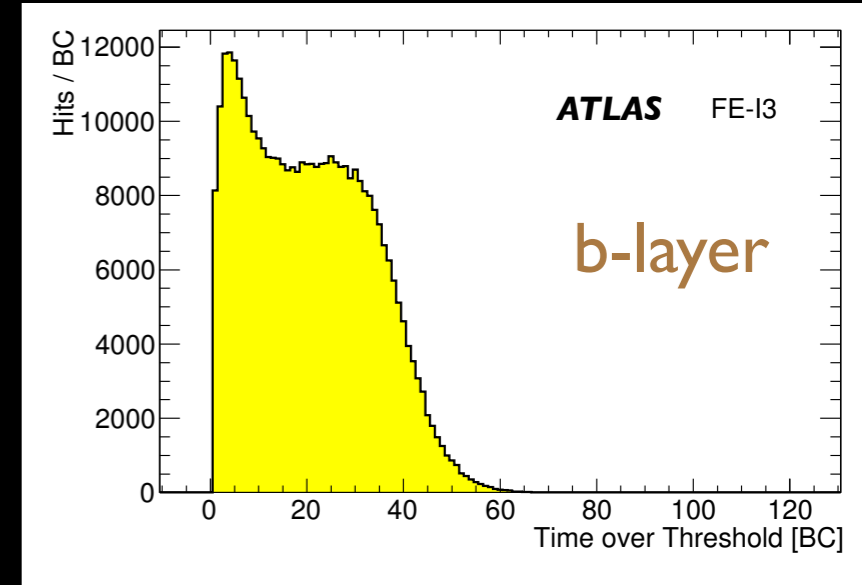

Tracking Performance (no Pileup)

- expected results

- ➔ smaller radius
- ➔ small z pitch
- ➔ less material between first and 2nd layer
- ➔ track length ~ same

- improvements

- ➔ better d_0 resolution
- ➔ better z_0 resolution
- ➔ θ and ϕ improved at low- p_T
- ➔ momentum resolution ~ unchanged

- as expected !

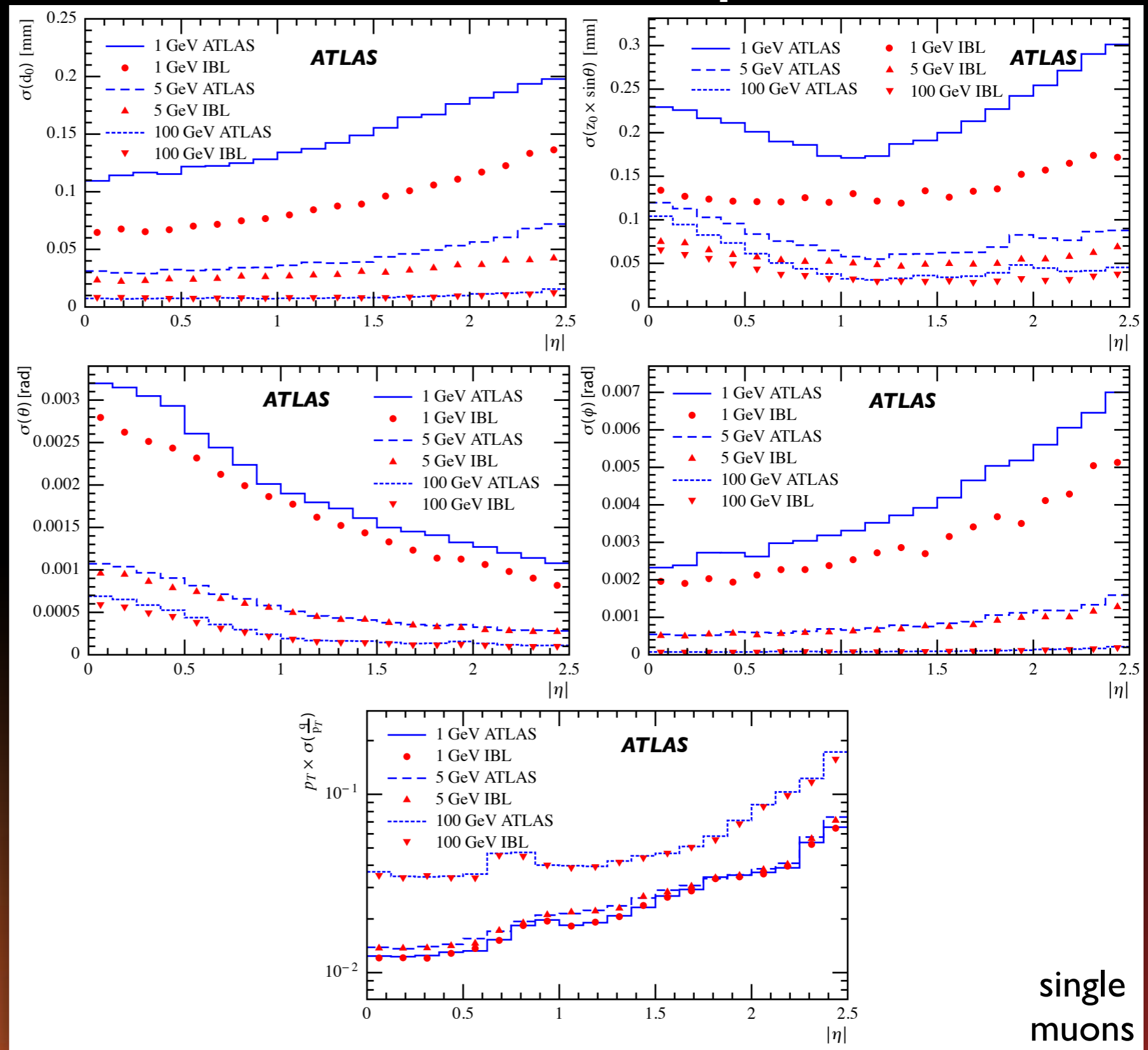

single muons



b-Tagging with IBL

- pileup selection with IBL
 - ➔ ≥ 10 IBL+Pixel+SCT hits, ≤ 1 pixel hole
 - ➔ benefit from additional layer
 - ➔ leaves room for eventual inefficiencies in b-layer (tracking robustness)
- state of the art b-tagging
 - ➔ "IP3D" $\sim d_0 \oplus z_0$ impact significance likelihood
 - ➔ "IP3D+SV1" \sim adding secondary vertex information
- good performance with IBL and pileup
 - ➔ as good or better as for current ATLAS without pileup

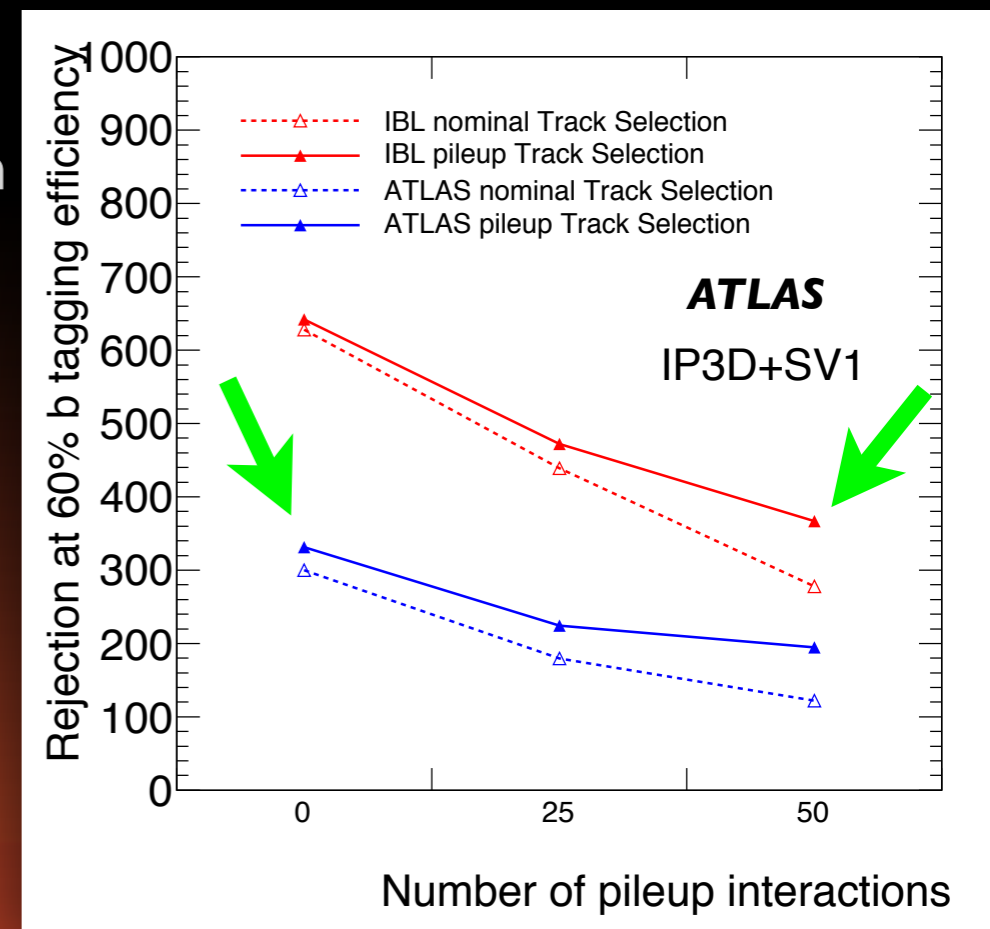
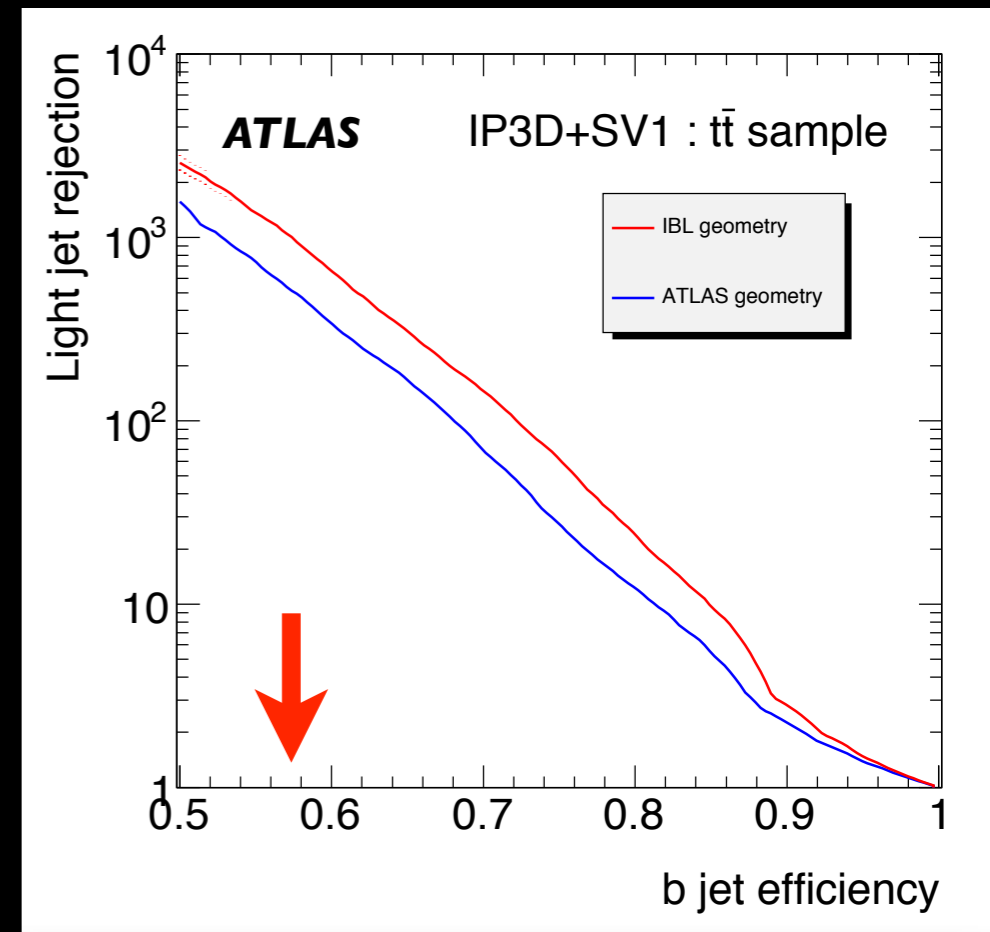

Detector Defects ?

- IBL helps to recover from detector defects
 - ➔ known bandwidth limitations of current FE-I3 chip leading to cluster inefficiencies
 - especially in b-layer ($r=4cm$)
 - ➔ layers 1 and 2 limited by readout links
 - may replace service quarter panels
 - ➔ eventual additional (known) dead modules
- study effect of 10% cluster inefficiency in b-layer with IBL
 - ➔ IBL fully recovers tracking efficiency and impact resolution
 - ➔ with IBL only small effects on b-tagging performance
 - ➔ similar results for other failure scenarios

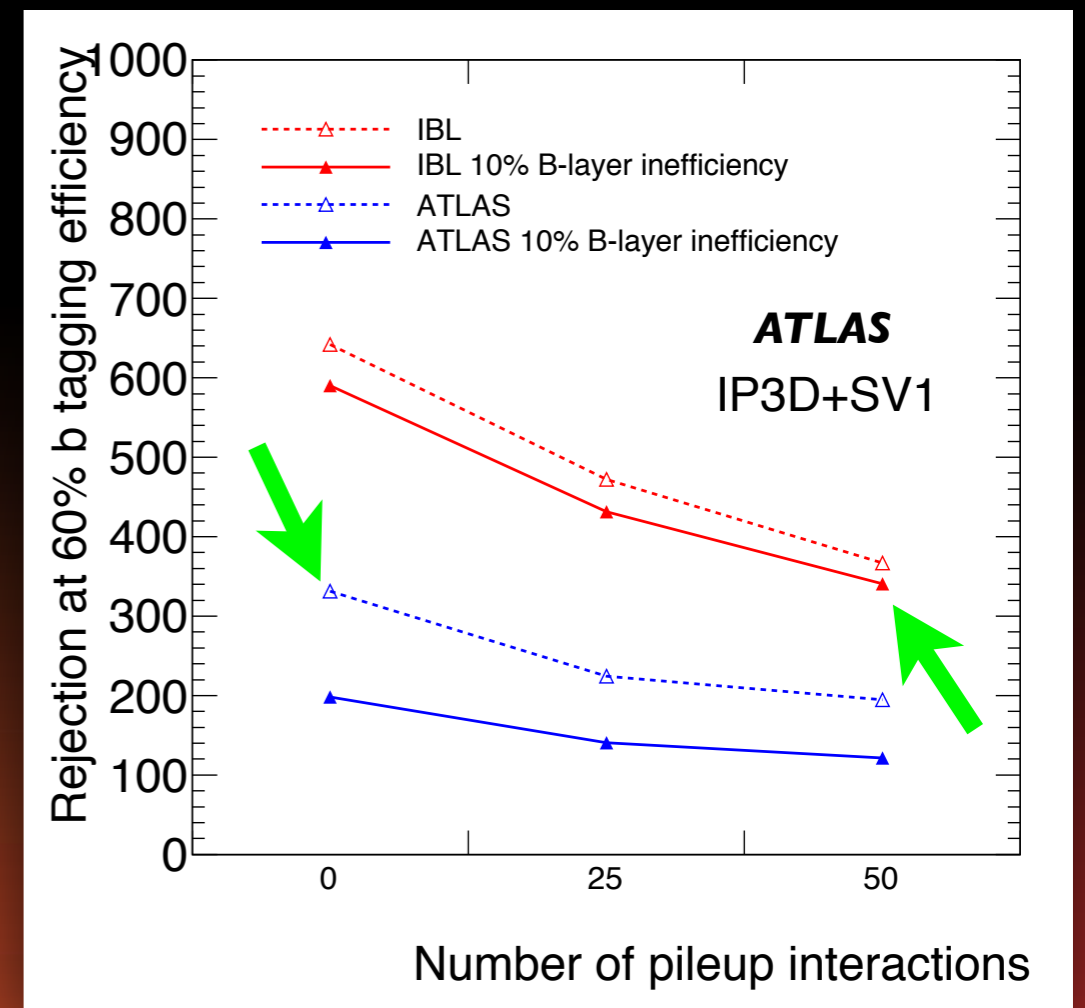
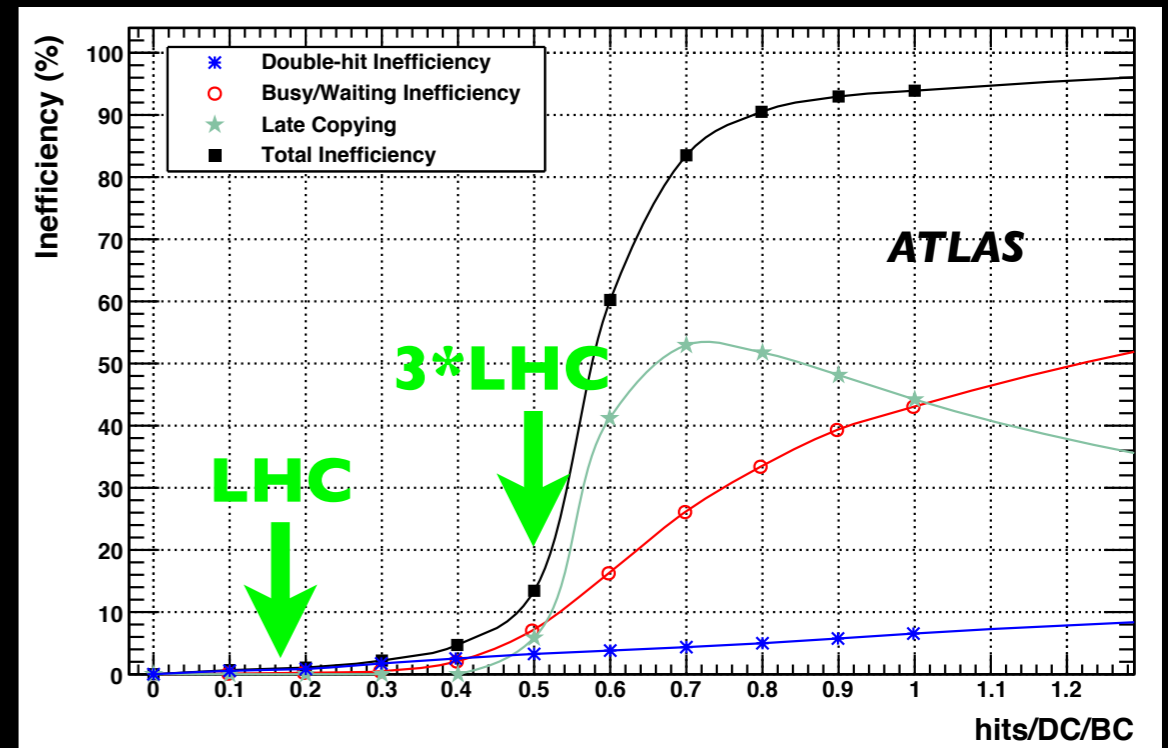

ATLAS Hardware Trigger Tracking (FTK)

- goal is to provide high quality tracks at input to High Level Trigger
 - ➔ FTK runs at nominal 100 kHz Level-1 trigger rate
- physics motivation
 - ➔ b and τ tagging, lepton isolation, improve Level-2 rejection at high lumi.
- requires hardware system with special readout links

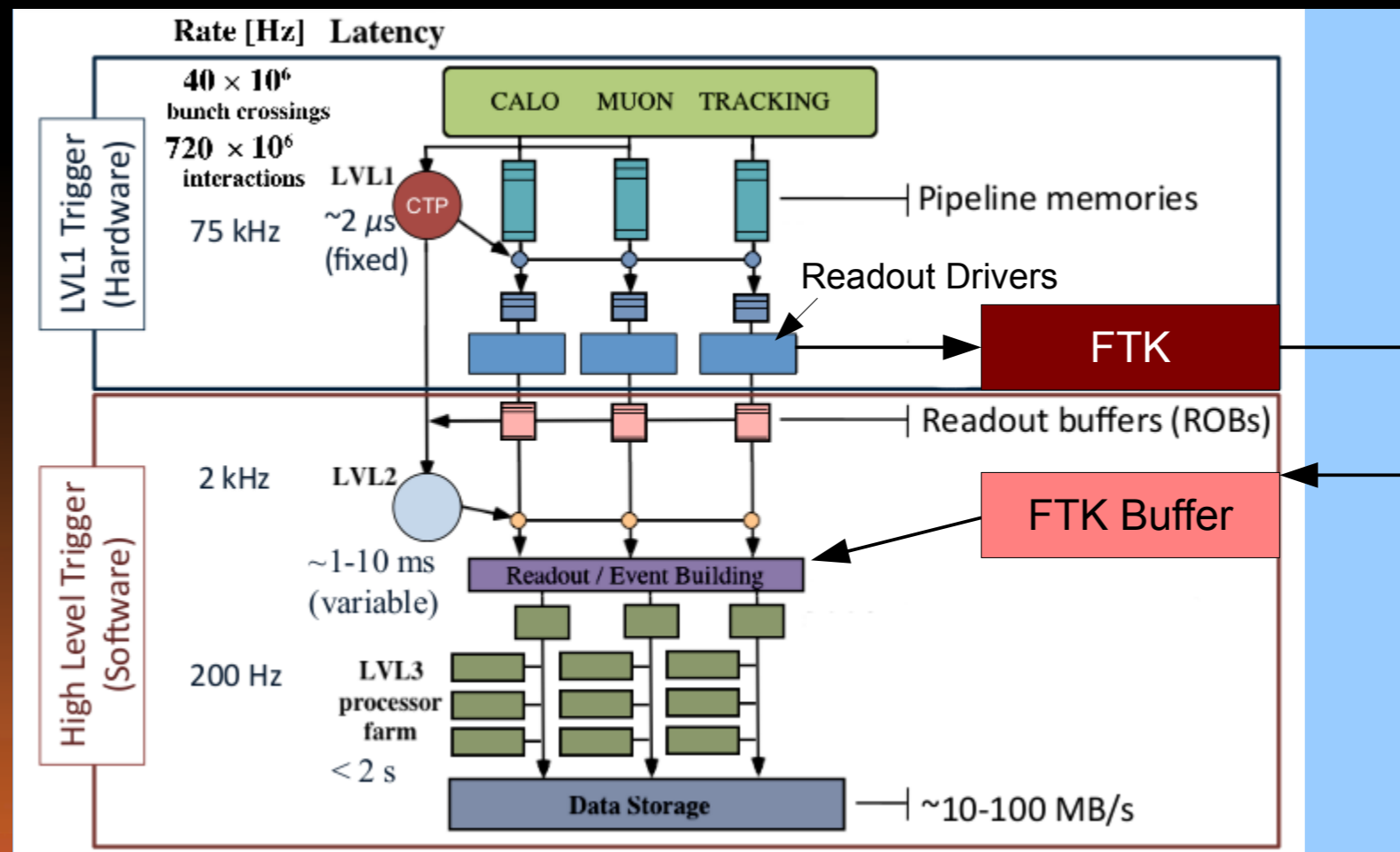

FTK - Overview

- architecture follows CDF

- ➔ Data formatter
 - clustering, routing to η - ϕ towers
- ➔ Data organizer (DO)
 - stores hits, communicates between pattern recognition and track fitting
- ➔ Associative Memory (AM) board
 - Pattern recognition
- ➔ track Fitter (TF)
 - FPGA-based track fitting

- associative memory

- ➔ millions of predefined hit patterns
- ➔ hits are evaluated against all patterns in parallel, leading to high timing gains !

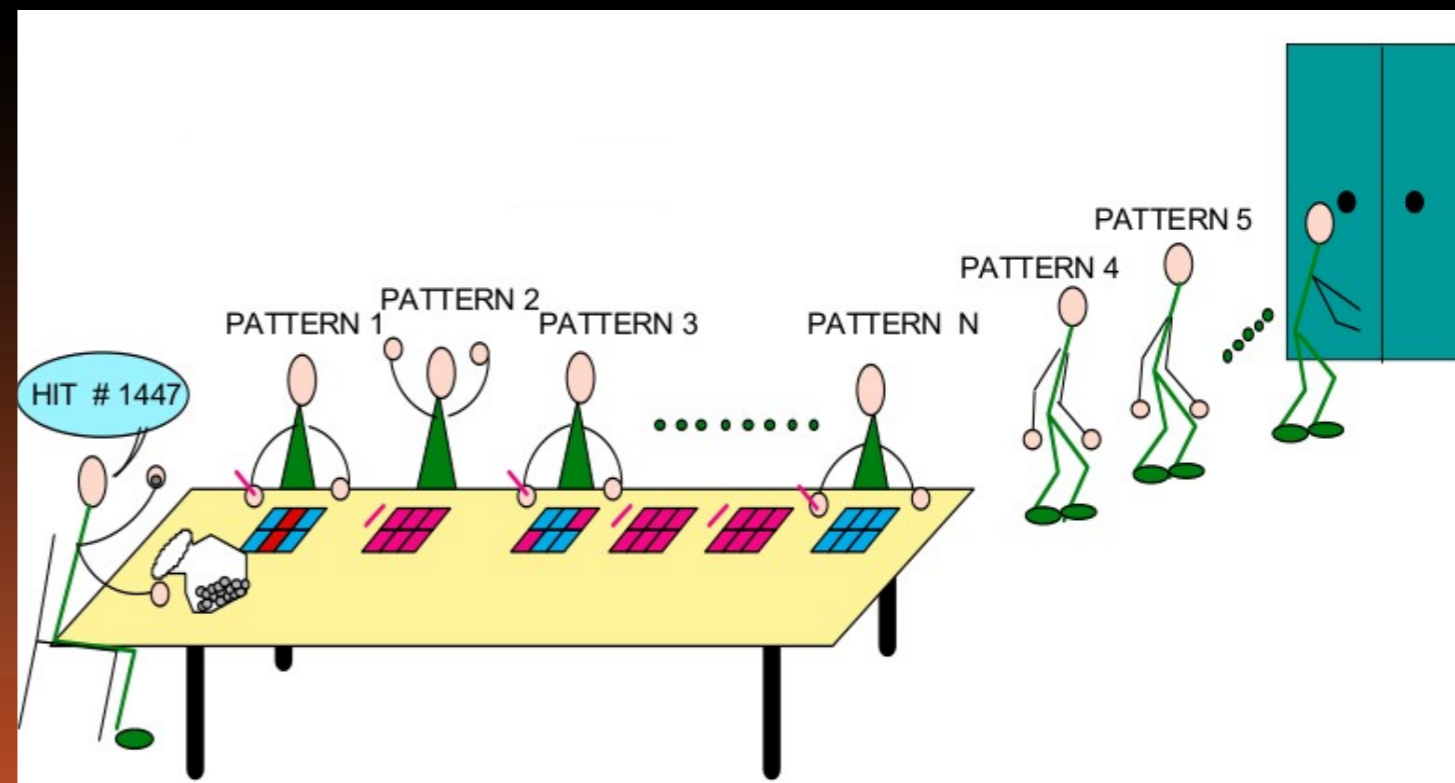
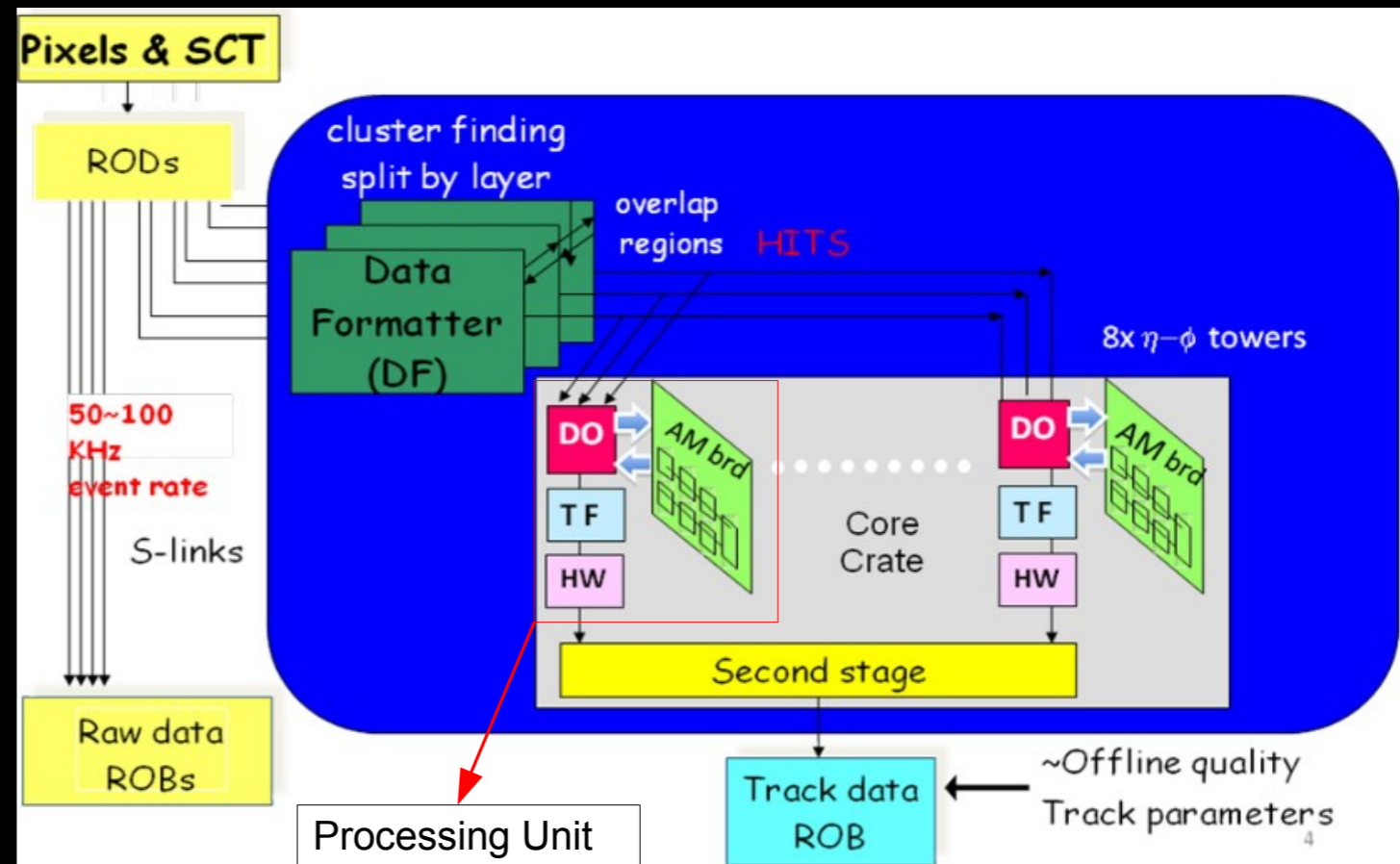

FTK - Overview

- fast track fitting

- ➔ divide detector in regions
- ➔ approximate track fit by a linear equation
- ➔ determine constants using full resolution in those regions (from offline)
- ➔ implement in FPGA chips, track fit ~ 1 nsec (full ~ 1 msec)

$$p_i = \sum_j c_{ij} \cdot x_j + q_i$$

Track parameters and χ^2 components Hit coordinates Constants

- performance

- ➔ timing for $H \rightarrow bb$ with 75 pileup, full scan, $p_T > 1$ GeV
- ➔ tracking efficiency $> 90\%$ compared to offline
- ➔ approximated track fit limits resolution of fit
- ➔ example: b-tagging performance at 75 pileup

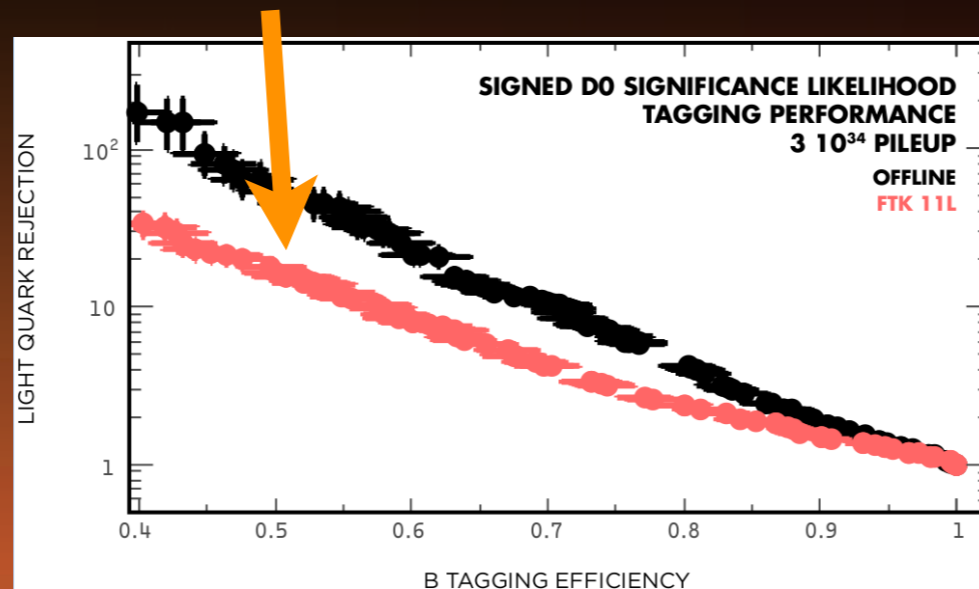
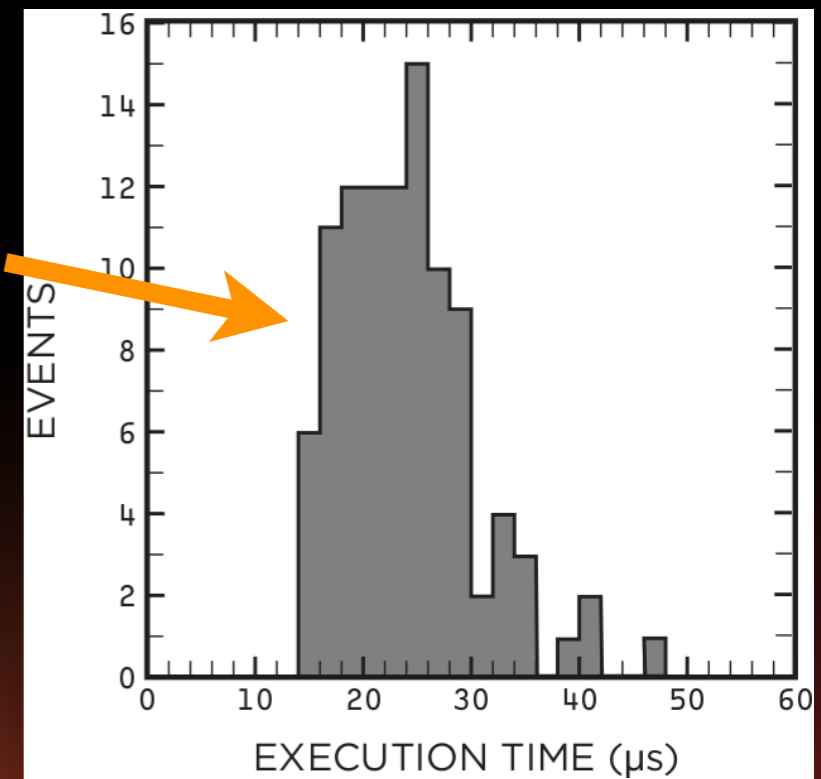

Outlook: GPU based Tracking

- SLHC: 150 to 200 pileup interactions
 - ➔ CPU for full event reconstruction increases dramatically
 - ➔ Inner Detector tracking will dominate completely
- obvious advantage of GPUs
 - ➔ benefit from rapid performance increase
- but: GPUs in GRID environment
 - ➔ only first prototype farms for software R&D
 - ➔ future integrated CPUs with GPU cores (?)
 - ➔ High Level Trigger farms better to customize
- prototype studies on GPU based tracking
 - ➔ implementation in CUDA (NVidia)
 - ➔ more advanced compared to OpenCL (preferred long term solution)

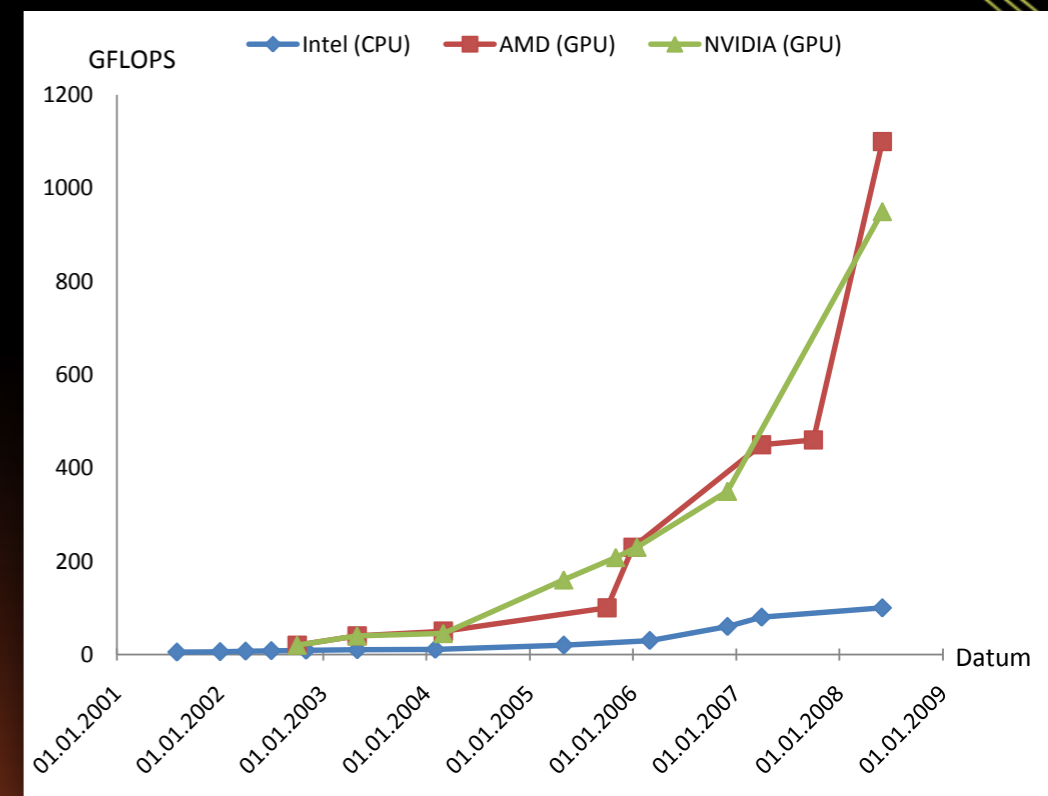

Outlook: GPU based Tracking

- first tracking prototypes for Level-2 track trigger and offline tracking
 - ➔ concentrate on aspects of track reconstruction chain
 - z-vertex finder
 - track seed finder
 - Kalman filter
 - ➔ early phase, still significant approximations
- very significant timing gains
 - ➔ lots of software development needed to obtain precision tracking
 - ➔ investigate mixed scenario ?
 - e.g. combinatorial seed finder on GPUs
 - CPUs for serial processing steps to do precision calculations

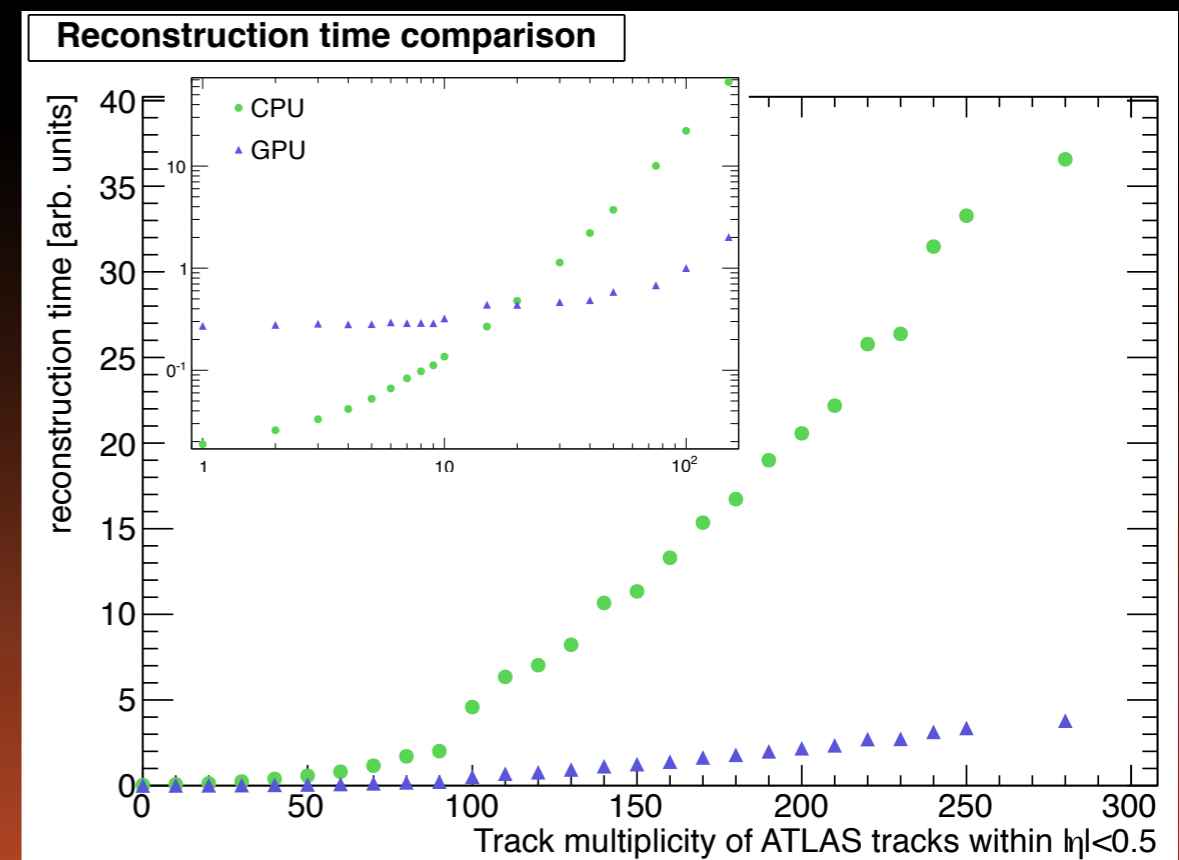
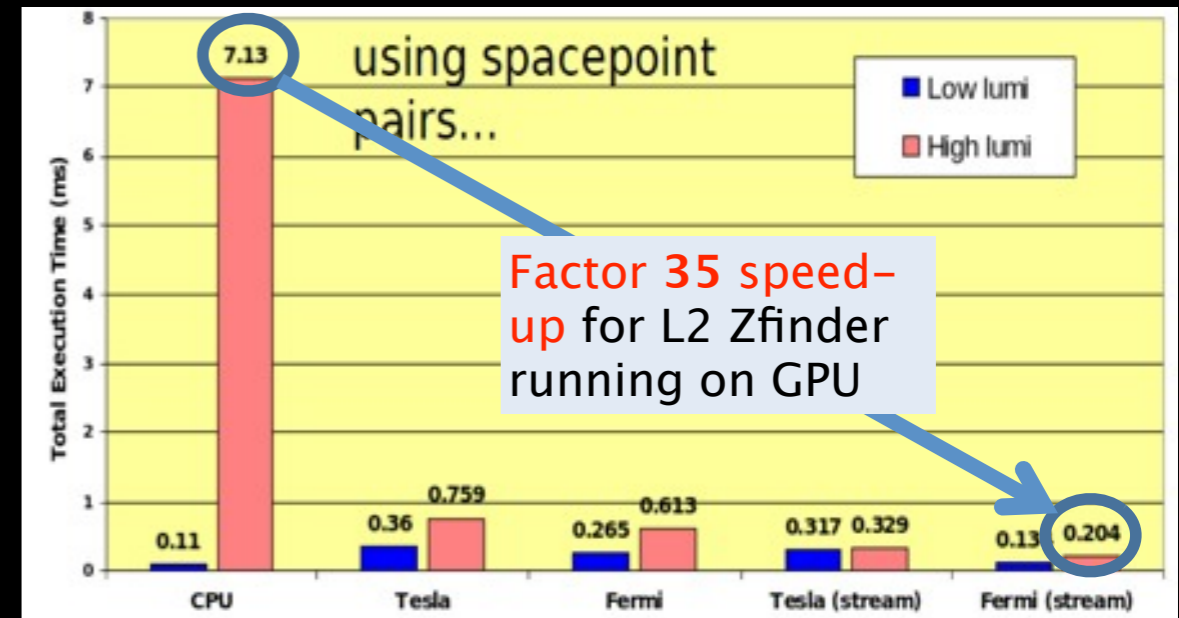

Summary

- stringent requirements on Inner Detector to cover ATLAS physics program
- excellent performance reached !
 - ➔ years of preparation based on simulation and test beam
 - ➔ commissioning with cosmics and early beam
 - ➔ detailed studies of detector, tracking, material, alignment, pileup...
 - ➔ Heavy Ion running gave good insights into tracking at high occupancy
- towards upgrade
 - ➔ tracking studies with IBL demonstrate performance of the detector with a 4 layer Pixel system at Phase 1 luminosities
 - ➔ FTK will provide fast tracking information for Level-2 trigger
 - ➔ towards SLHC: GPU based tracking studies

